

I&C FURNISH & INSTALL	I&C FURNISH MECHANICAL INSTALL	MANUFACTURER FURNISH MECHANICAL INSTALL
ELECTRICAL FURNISH & INSTALL	I&C FURNISH ELECTRICAL INSTALL	MANUFACTURER FURNISH ELECTRICAL INSTALL

PLEASE NOTE: Mechanical to install in-line instruments and sample panels. Electrician to install transmitters/stands and control panels

Rev 1 Notable Changes:

1. Changed the IT/Network equipment install scope to be responsible by the Electrician
2. Changed some highlights to provide more clarity on scope responsibilities

Rev 2 Notable Changes:

1. Remote Control Stations for Actuated Control Valves are to be furnished by I&C

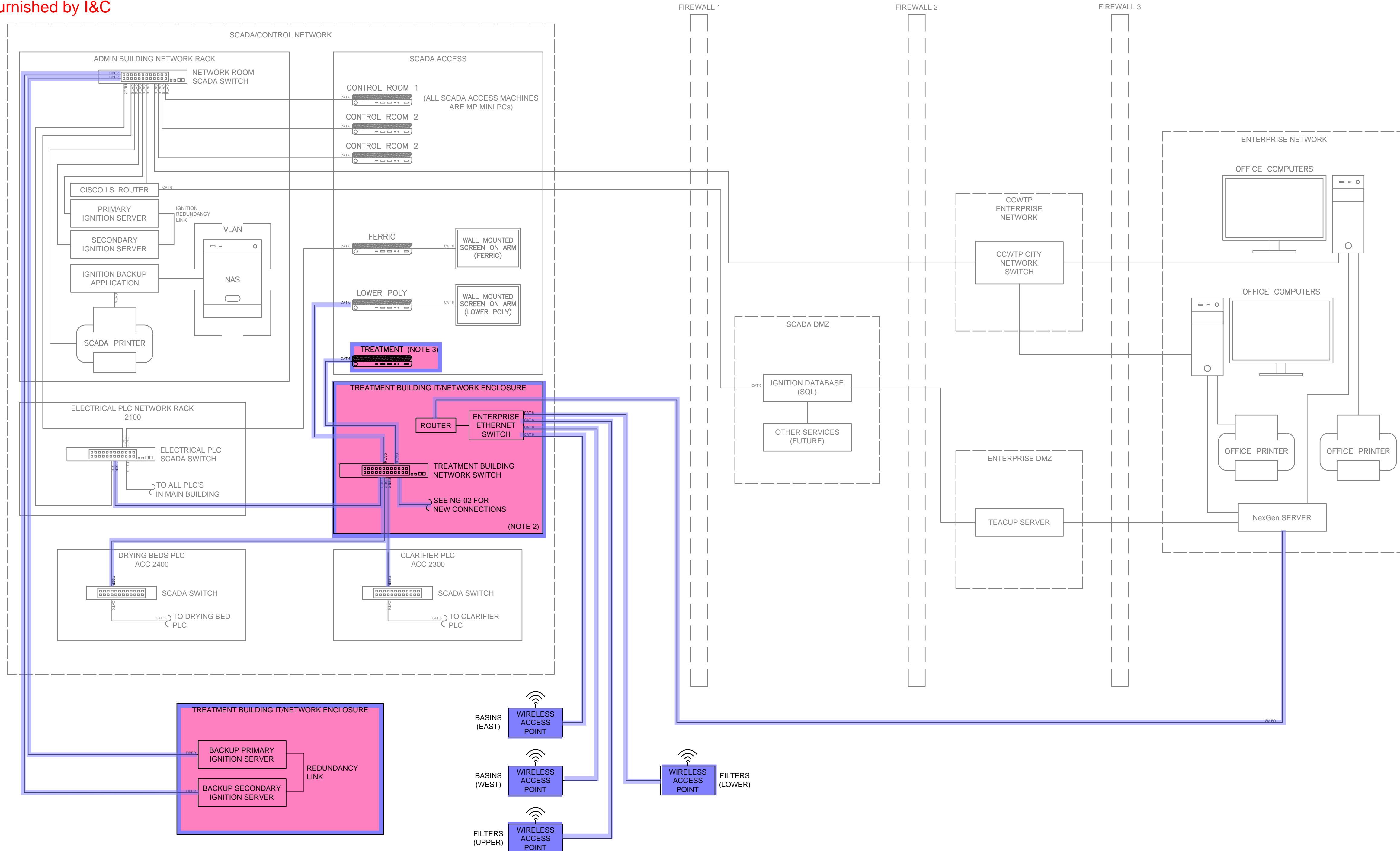

GENERAL NOTES:

1. WHERE REQUIRED, CONTRACTOR TO PROVIDE MEDIA CONVERTERS IN THE EXISTING ELECTRICAL PLC PATCH PANEL.
2. THE TREATMENT BUILDING PLC WILL EVENTUALLY REPLACE THE GENERAL FILTER PLC RACK (ACC 2200). NEW SM FO CABLE TO BE INSTALLED FROM THE TREATMENT BUILDING PLC TO THE EXISTING ELECTRICAL, DRYING BED, CLARIFIER AND LOWER POLY CONTROLLERS.
3. LOCATE SCADA CLIENT IN LOWER LEVEL OF TREATMENT BUILDING IN ROOM BENEATH THE HVAC ROOM.

DESIGNED BY: BOTANI	SCALE:
DRAWN BY: ALAPIERRE	
CHECKED BY: J.PAGENDARM	
APPROVED BY: BOTANI	
DATE: JUNE 2024	
EWO NO: ---	
ACCOUNT NO: 512260079	

REVISIONS

NO.	DATE	ISSUED FOR	GUARANTEE	MAXIMUM PRICE (GMP)
0	06/14/24			

SALT LAKE CITY DEPARTMENT OF PUBLIC UTILITIES
CITY CREEK TREATMENT PLANT UPGRADES
BRIC PACKAGE
NETWORK DIAGRAM

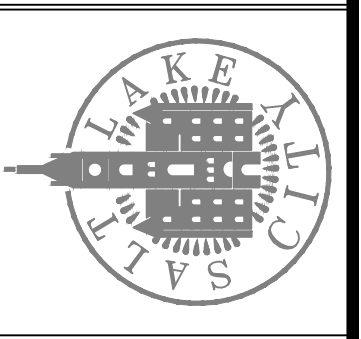

90% GMP

DRAWING NO.
NG-01

Brown and Caldwell

C:\Users\alapierre\AppData\Local\Autodesk\AutoCAD Plant_3D\CollaborationCache\153020-SLICDPL_City_Creek_WTP-v2021\PID_DWG\NG-01.dwg Jun 12, 2024 - 2:34pm

C:\Users\alapierre\AppData\Local\Autodesk\AutoCAD Plant_3D\Collaboration\153020-SLDCIPUL_City_Creek_WTP-V2021\FID_DWG\NG-02.dwg Jun 12, 2024 - 2:36pm

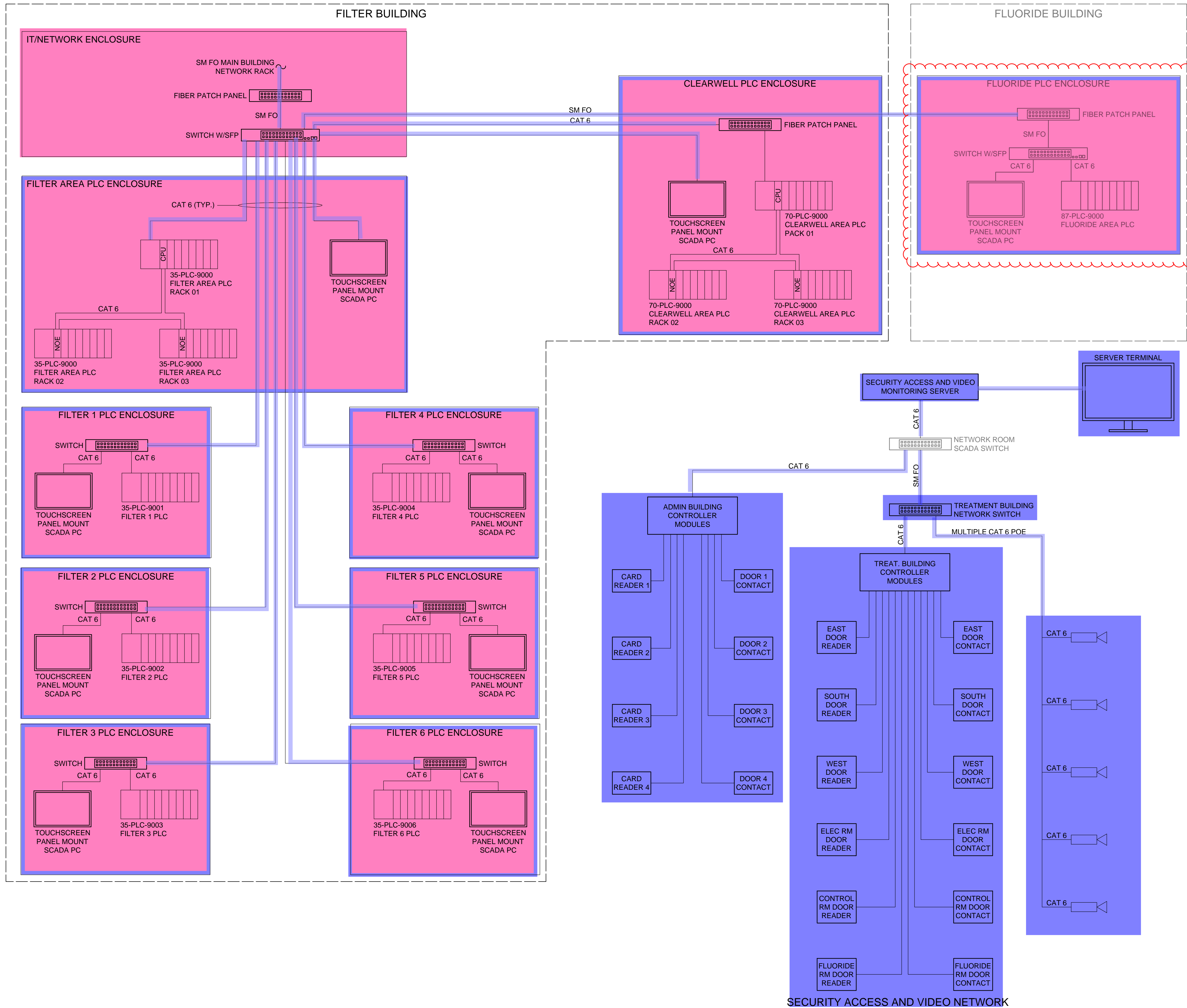

RFI: is this new or existing?

DESIGNED BY: BOTANI
 DRAWN BY: ALAPIERRE
 CHECKED BY: J.PAGENDARM
 APPROVED BY: BOTANI
 DATE: JUNE 2024
 EMO NO: ---
 ACCOUNT NO: 512260079

SCALE: ---

VERIFY SCALE
 BAR IS ONE INCH ON ORIGINAL DRAWING

NO.	DATE	REVISIONS
0	06/14/24	ISSUED FOR GUARANTEE MAXIMUM PRICE (GMP)

SALT LAKE CITY DEPARTMENT OF PUBLIC UTILITIES
 CITY CREEK TREATMENT PLANT UPGRADES
 BRIC PACKAGE
NETWORK DIAGRAM

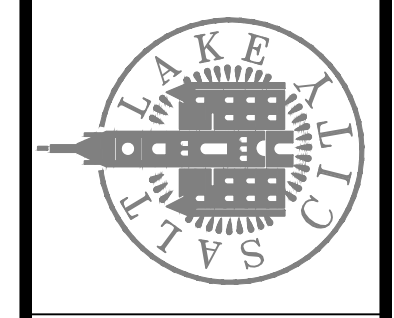

Brown and Caldwell

90% GMP

DRAWING NO.
NG-02

C:\Users\alapiere\AppData\Local\Autodesk\AutoCAD Plant_3D\CollaborationCache\153020-SLICDPL_City_Creek_WTP-V2021\PID_DWG\01-PI-01.dwg Jun 21, 2024 -- 11:40am

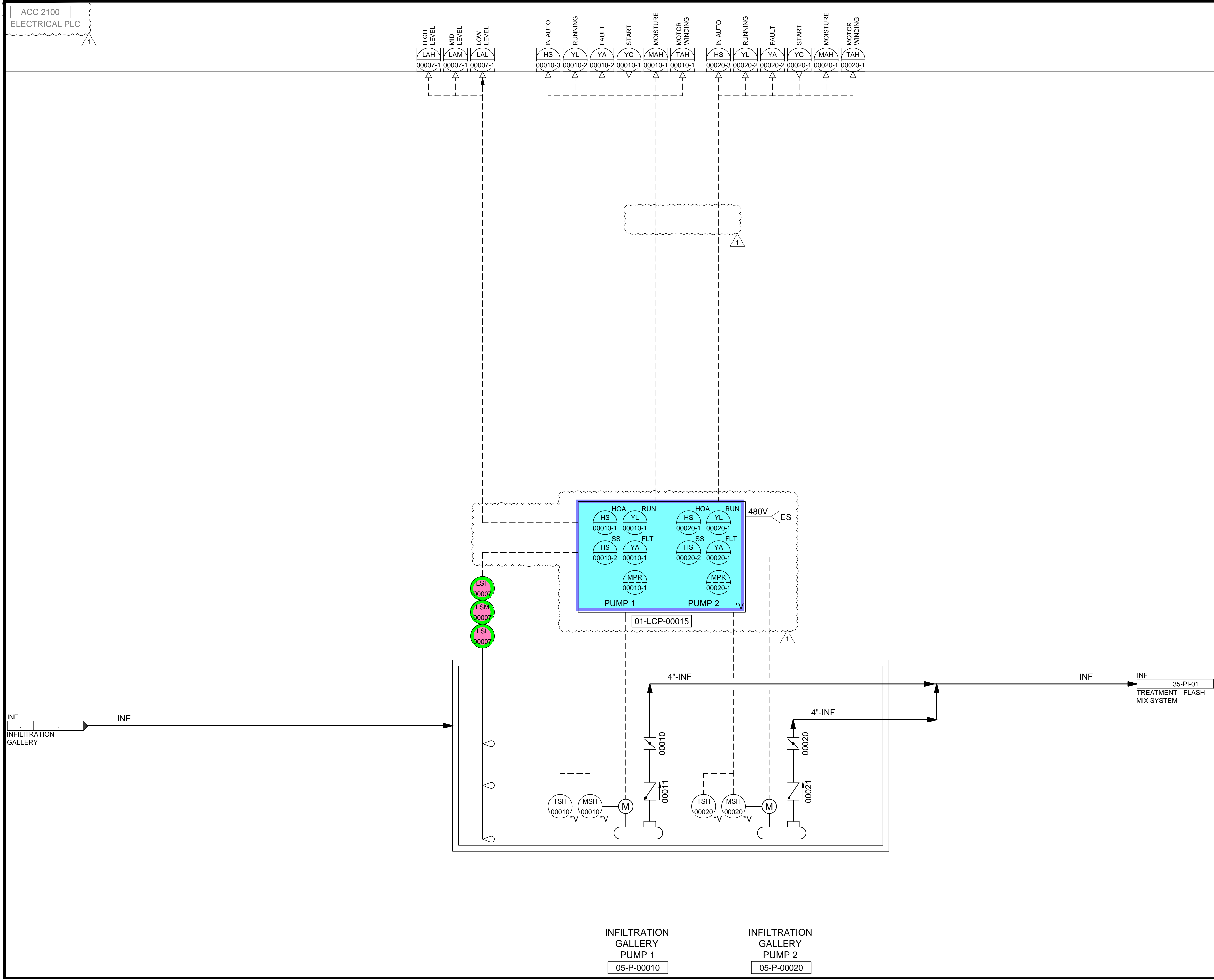

Brown and Caldwell

SALT LAKE CITY DEPARTMENT OF PUBLIC UTILITIES
 CITY CREEK TREATMENT PLANT UPGRADES
 BRIC PACKAGE
INFILTRATION GALLERY PUMP STATION

DESIGNED BY: BOTANI
 DRAWN BY: ALAPIERE
 CHECKED BY: J.PAGENDARM
 APPROVED BY: BOTANI
 DATE: JUNE 2024
 EWO NO: ---
 ACCOUNT NO: 512260079

SCALE: _____

REVISIONS

NO.	DATE	ISSUED FOR	GUARANTEE	MAXIMUM PRICE (GMP)
0	06/14/24	ISSUED FOR	GUARANTEE	MAXIMUM PRICE (GMP)
1	06/27/24	REVISED FOR	GUARANTEE	MAXIMUM PRICE (GMP)

MADE BY: BO
 AUTH BY: BO

VERIFY SCALE
 BAR IS ONE INCH ON ORIGINAL DRAWING

DRAWING NO.
01-PI-01

90% GMP

C:\Users\alopierre\AppData\Local\Autodesk\AutoCAD Plant_3D\CollaborationCache\153020-SLCCDPL_City_Creek_WTP-v2021\PID_DWG\03-PI-01.dwg Jun 25, 2024 -- 11:05am

ACC 2101
CHEMICAL PLC

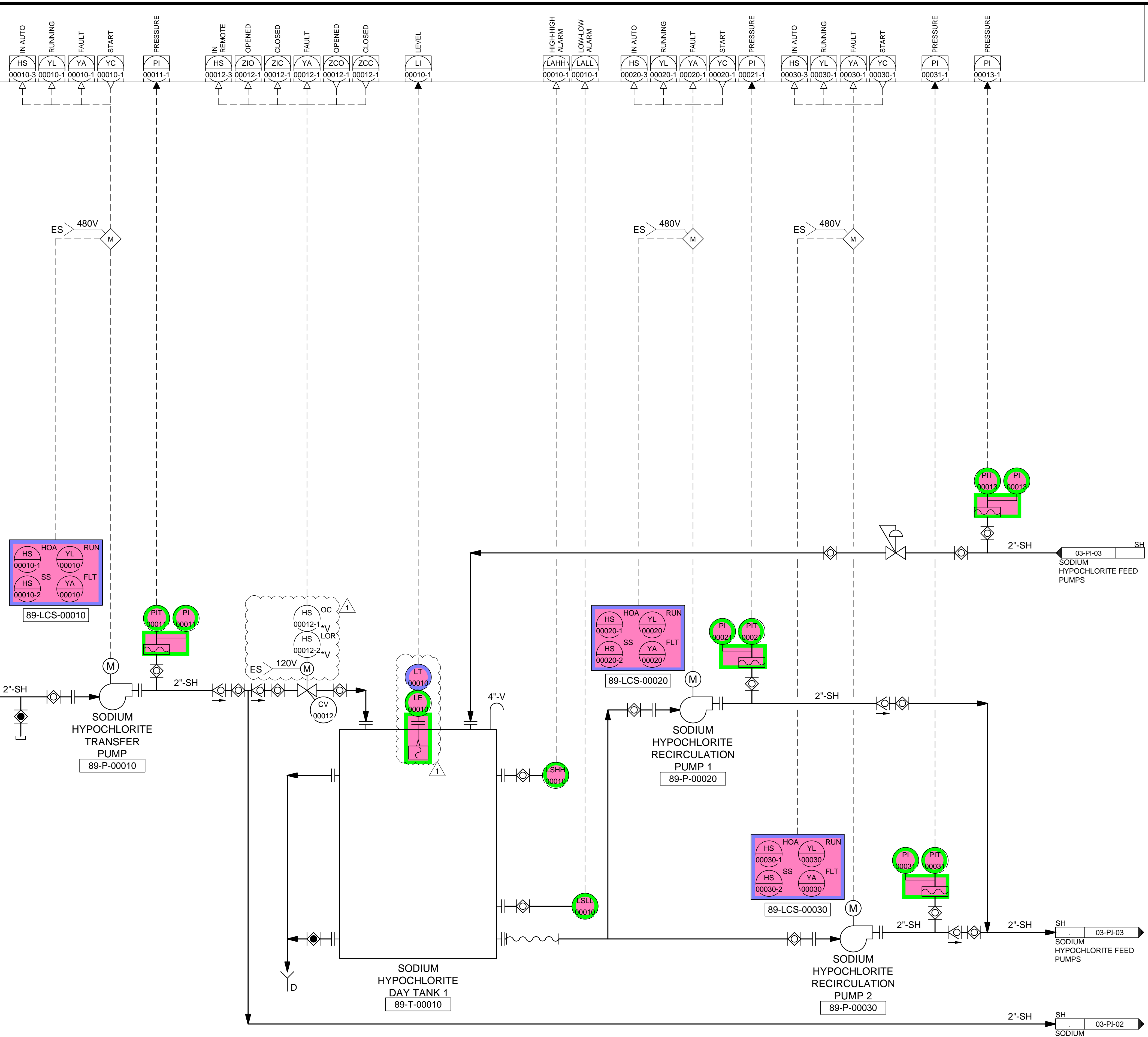

DESIGNED BY: BOTANI
 DRAWN BY: ALAPIERRE
 CHECKED BY: ALPAGENDARM
 APPROVED BY: BOTANI
 DATE: JUNE 2024
 EMO NO: ---
 ACCOUNT NO: 512260079

SCALE: _____

VERIFY SCALE
 BAR IS ONE INCH ON ORIGINAL DRAWING

NO.	DATE	REVISIONS
0	06/14/24	ISSUED FOR GUARANTEE MAXIMUM PRICE (GMP)
1	06/27/24	REVISED FOR GUARANTEE MAXIMUM PRICE (GMP)

SALT LAKE CITY DEPARTMENT OF PUBLIC UTILITIES
 CITY CREEK TREATMENT PLANT UPGRADES
 BRIC PACKAGE
**SODIUM HYPOCHLORITE
 RECIRCULATION LOOP 1**

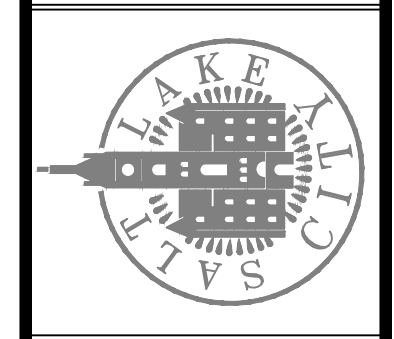

90% GMP

DRAWING NO.
03-PI-01

Brown and Caldwell

C:\Users\alapiere\AppData\Local\Autodesk\AutoCAD Plant_3D\CollaborationCache\153020-SLICDPL_City_Creek_WTP-v2021\PID_DWG\03-PI-02.dwg Jun 25, 2024 -- 11:05am

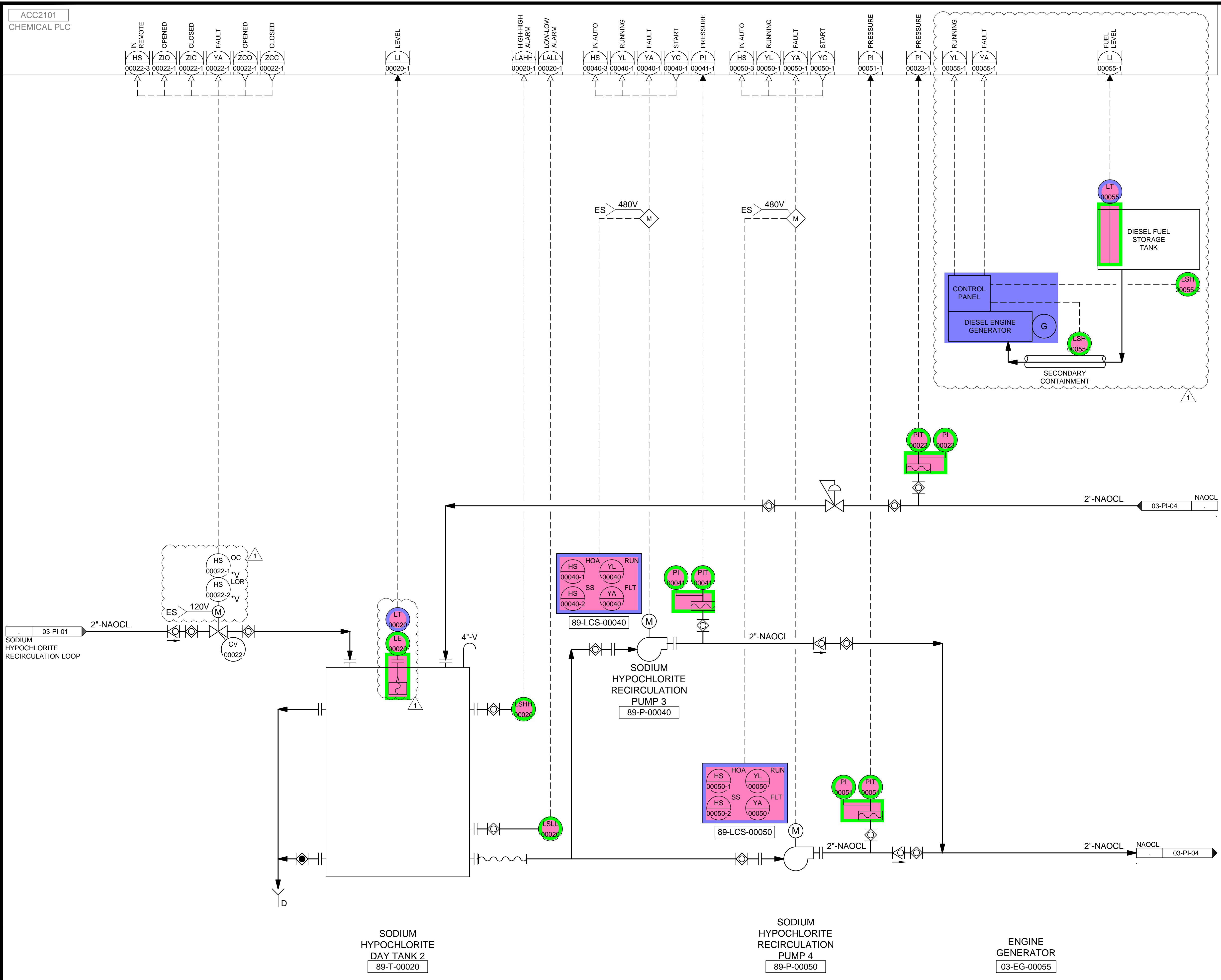

ACC2101
CHEMICAL PLC

DESIGNED BY: BOTANI
DRAWN BY: ALAPIERE
CHECKED BY: ALPAGENDARM
APPROVED BY: BOTANI
DATE: JUNE 2024
EWO NO: 51226079
ACCOUNT NO: 51226079

SCALE: _____

VERIFY SCALE
BAR IS ONE INCH ON ORIGINAL DRAWING

NO.	DATE	REVISIONS
0	06/14/24	ISSUED FOR GUARANTEE MAXIMUM PRICE (GMP)
1	06/27/24	REVISED FOR GUARANTEE MAXIMUM PRICE (GMP)

SALT LAKE CITY DEPARTMENT OF PUBLIC UTILITIES
CITY CREEK TREATMENT PLANT UPGRADES
BRIC PACKAGE
**SODIUM HYPOCHLORITE
RECIRCULATION LOOP 2**

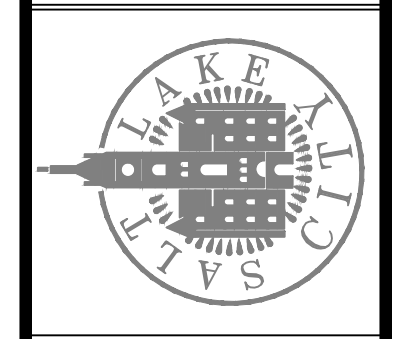

90% GMP

DRAWING NO.
03-PI-02

Brown and Caldwell

C:\Users\alapiere\AppData\Local\Autodesk\AutoCAD Plant_3D\CollaborationCache\153020-SLICDPL_City_Creek_WTP-V2021\PID_DWG\03-PI-03.dwg Jun 13, 2024 - 8:30am

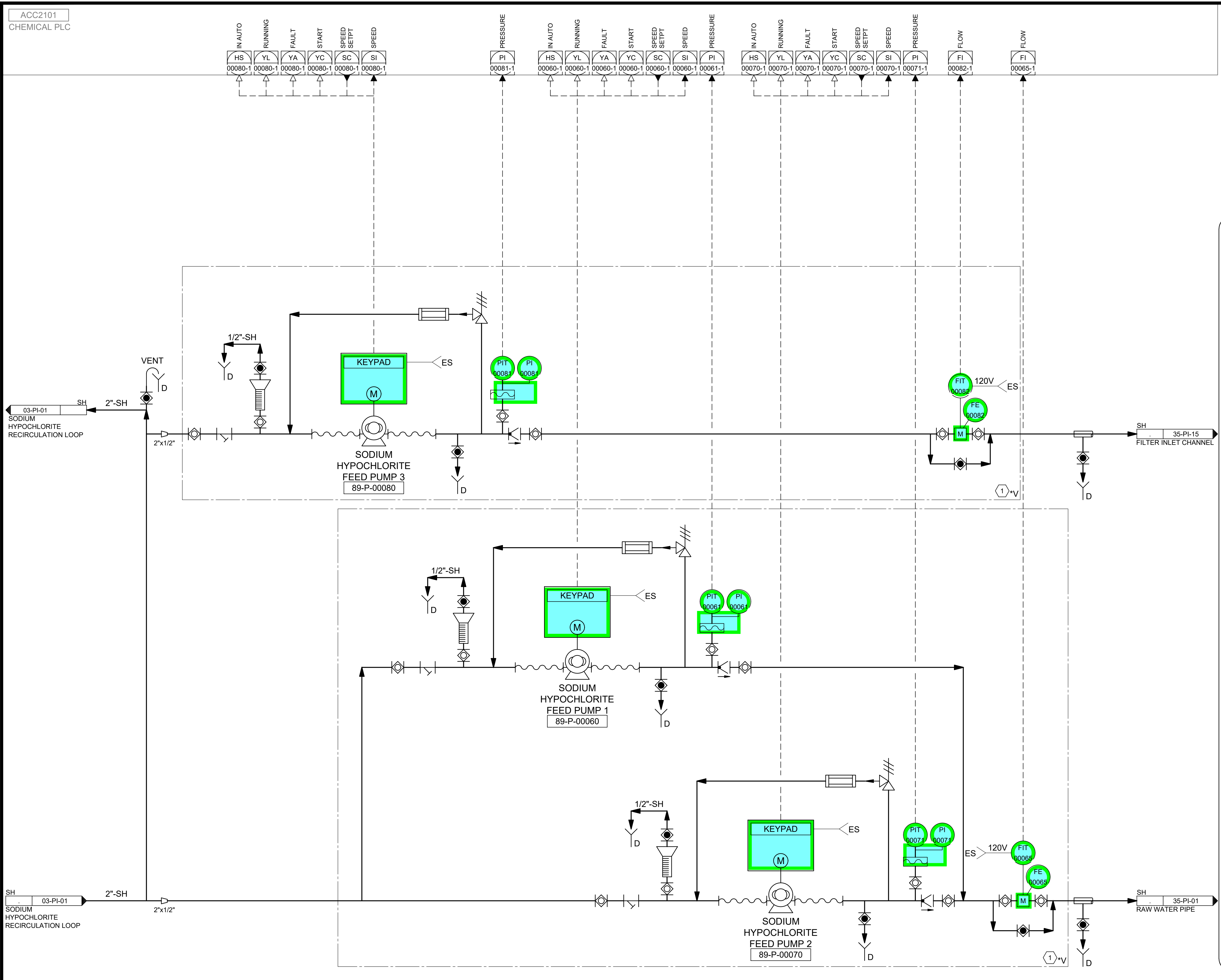

ACC2101 CHEMICAL PLC	IN AUTO 00080-1	RUNNING 00080-1	FAULT 00080-1	START 00080-1	SPEED SETPT 00080-1	SPEED 00080-1	PI 00081-1	IN AUTO 00060-1	RUNNING 00060-1	FAULT 00060-1	START 00060-1	SPEED SETPT 00060-1	SPEED 00060-1	PI 00061-1	IN AUTO 00070-1	RUNNING 00070-1	FAULT 00070-1	START 00070-1	SPEED SETPT 00070-1	SPEED 00070-1	PI 00071-1	FI 00082-1	FI 00065-1
-------------------------	--------------------	--------------------	------------------	------------------	------------------------	------------------	---------------	--------------------	--------------------	------------------	------------------	------------------------	------------------	---------------	--------------------	--------------------	------------------	------------------	------------------------	------------------	---------------	---------------	---------------

KEYNOTES:

1 VENDOR PACKAGED CHEMICAL PUMP SKID, SEE SECTION 46 33 44.

DESIGNED BY: BOTANI	AUTH. BY: BO
DRAWN BY: ALAPIERE	MADE BY: BO
CHECKED BY: J.PAGENDARM	DATE: JUNE 2024
APPROVED BY: BOTANI	DATE: JUNE 2024
EWO NO: 512260079	ACCOUNT NO: 512260079

SCALE: _____

VERIFY SCALE
BAR IS ONE INCH ON ORIGINAL DRAWING

REVISIONS

NO.	DATE	ISSUED FOR	GUARANTEE	MAXIMUM PRICE (GMP)
0	06/14/24	ISSUED FOR	GUARANTEE	MAXIMUM PRICE (GMP)

SALT LAKE CITY DEPARTMENT OF PUBLIC UTILITIES
CITY CREEK TREATMENT PLANT UPGRADES
BRIC PACKAGE
SODIUM HYPOCHLORITE FEED
1

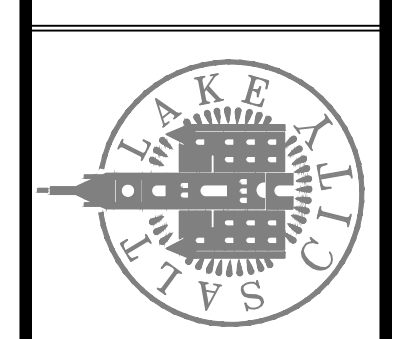

90% GMP

DRAWING NO.
03-PI-03

Brown and Caldwell

C:\Users\alapiere\AppData\Local\Autodesk\AutoCAD Plant_3D\CollaborationCache\153020-SLICDPL_City_Creek_WTP-V2021\PID_DWG\03-PI-04.dwg Jun 12, 2024 - 2:39pm

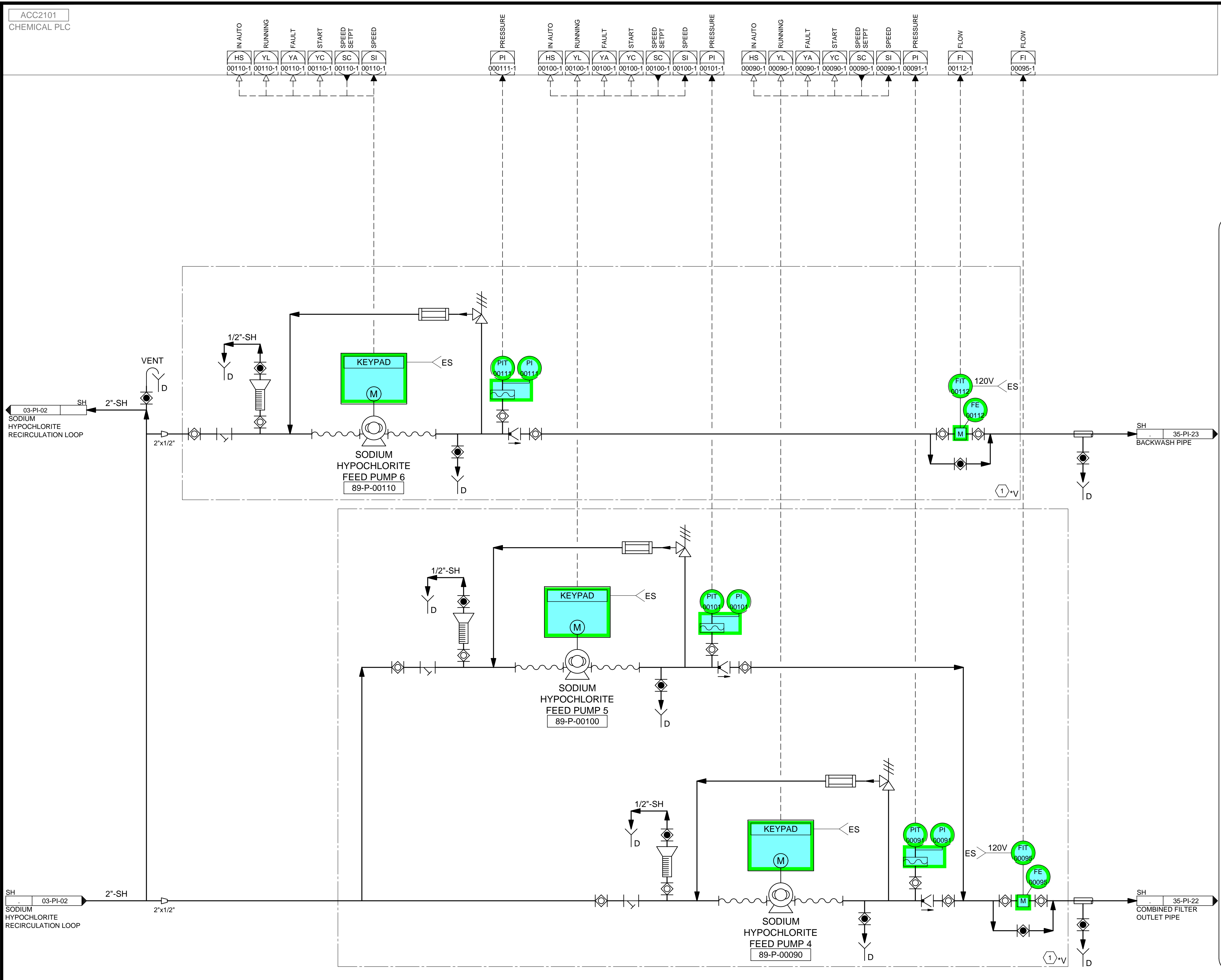

ACC2101 CHEMICAL PLC	IN AUTO HS 00110-1	RUNNING YL 00110-1	FAULT YA 00110-1	START YC 00110-1	SPEED SETPT SC 00110-1	SPEED SI 00110-1	PI 00111-1	IN AUTO HS 00100-1	RUNNING YL 00100-1	FAULT YA 00100-1	START YC 00100-1	SPEED SETPT SC 00100-1	SPEED SI 00100-1	PI 00101-1	IN AUTO HS 00090-1	RUNNING YL 00090-1	FAULT YA 00090-1	START YC 00090-1	SPEED SETPT SC 00090-1	SPEED SI 00090-1	PI 00091-1	FI 00112-1	FI 00095-1
-------------------------	--------------------------	--------------------------	------------------------	------------------------	------------------------------	------------------------	---------------	--------------------------	--------------------------	------------------------	------------------------	------------------------------	------------------------	---------------	--------------------------	--------------------------	------------------------	------------------------	------------------------------	------------------------	---------------	---------------	---------------

KEYNOTES:

1 VENDOR PACKAGED CHEMICAL PUMP SKID, SEE SECTION 46 33 44.

DESIGNED BY: BOTANI	AUTH. BY: BO
DRAWN BY: ALAPIERE	MADE BY: BO
CHECKED BY: J.PAGENDARM	DATE: JUNE 2024
APPROVED BY: BOTANI	DATE: JUNE 2024
EWO NO: ---	ACCOUNT NO: 512260079

SCALE: ---

VERIFY SCALE
BAR IS ONE INCH ON ORIGINAL DRAWING

REVISIONS

NO.	DATE	ISSUED FOR	GUARANTEE	MAXIMUM PRICE (GMP)
0	06/14/24	ISSUED FOR	GUARANTEE	MAXIMUM PRICE (GMP)

SALT LAKE CITY DEPARTMENT OF PUBLIC UTILITIES
CITY CREEK TREATMENT PLANT UPGRADES
BRIC PACKAGE
SODIUM HYPOCHLORITE FEED
2

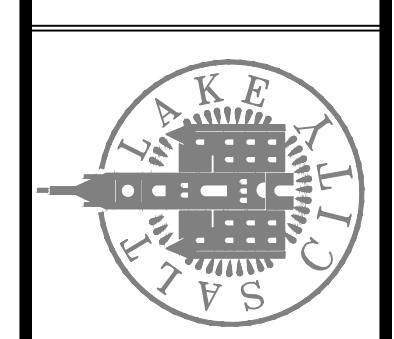

90% GMP

DRAWING NO.
03-PI-04

Brown and Caldwell

C:\Users\alapiere\AppData\Local\Autodesk\AutoCAD Plant_3D\CollaborationCache\153020-SLICDPL_City_Creek_WTP-V2021\PID_DWG\35-PI-01.dwg Jun 12, 2024 -- 3:38pm

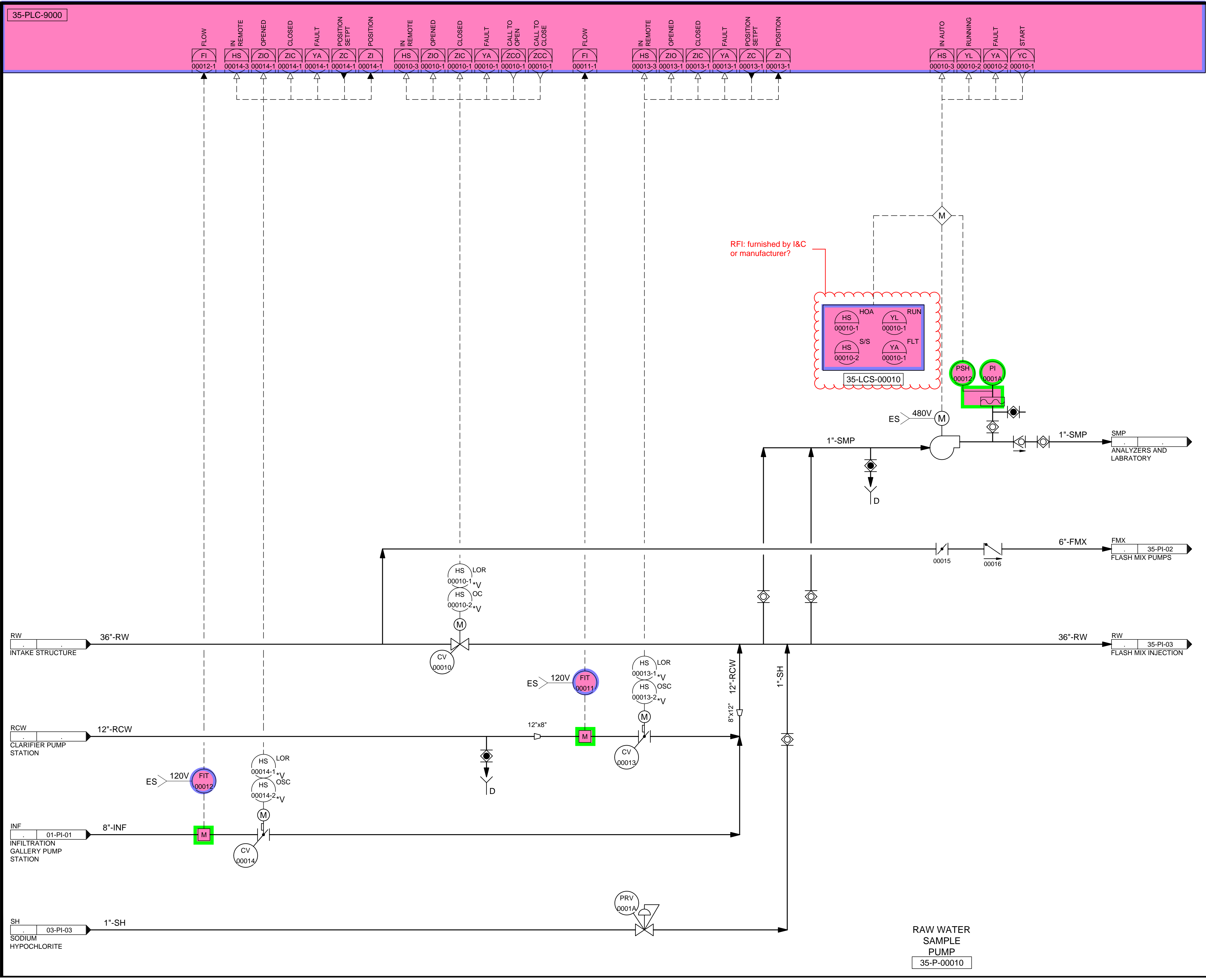

35-PLC-9000

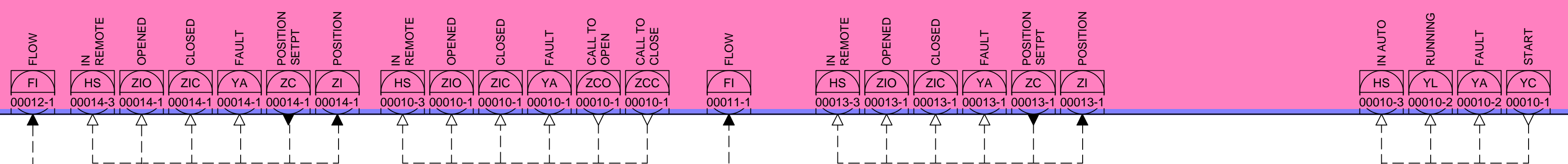

RFI: furnished by I&C or manufacturer?

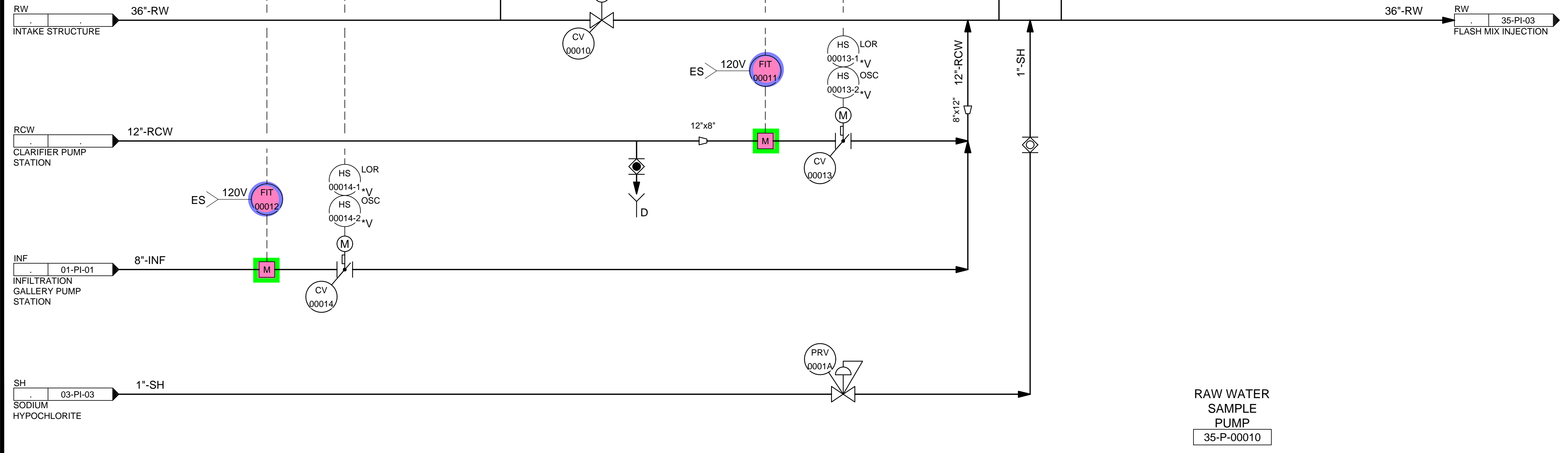
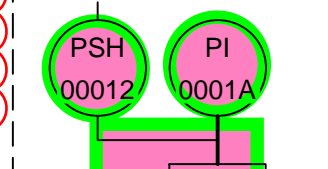
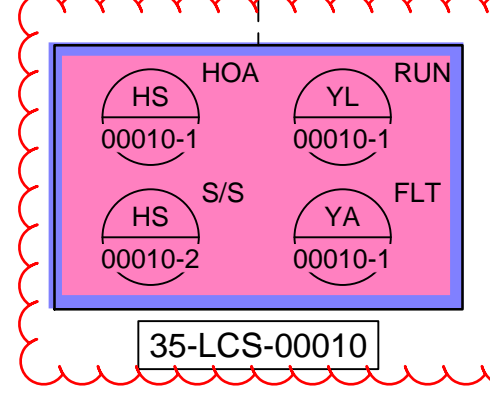

RAW WATER SAMPLE PUMP
35-P-00010

Brown and Caldwell

REVISIONS		DESIGNED BY:	AUTH. BY:
NO.	DATE	BO	BO
0	06/14/24	ISSUED FOR GUARANTEE MAXIMUM PRICE (GMP)	

SALT LAKE CITY DEPARTMENT OF PUBLIC UTILITIES
CITY CREEK TREATMENT PLANT UPGRADES
BRIC PACKAGE
TREATMENT - FLASH MIX SYSTEM

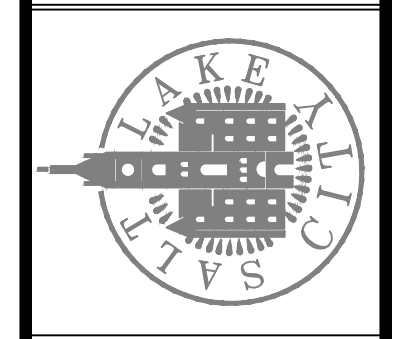

90% GMP

DRAWING NO.
35-PI-01

SCALE:
DESIGNED BY: BOTANI
DRAWN BY: ALAPIERE
CHECKED BY: J.PAGENDARM
APPROVED BY: BOTANI
DATE: JUNE 2024
EWO NO: --
ACCOUNT NO: 512260079

VERIFY SCALE
BAR IS ONE INCH ON ORIGINAL DRAWING

C:\Users\alapiere\AppData\Local\Autodesk\AutoCAD Plant_3D\CollaborationCache\153020-SLICDPL_City_Creek_WTP-V2021\PID_DWG\35-PI-02.dwg Jun 24, 2024 -- 9:08am

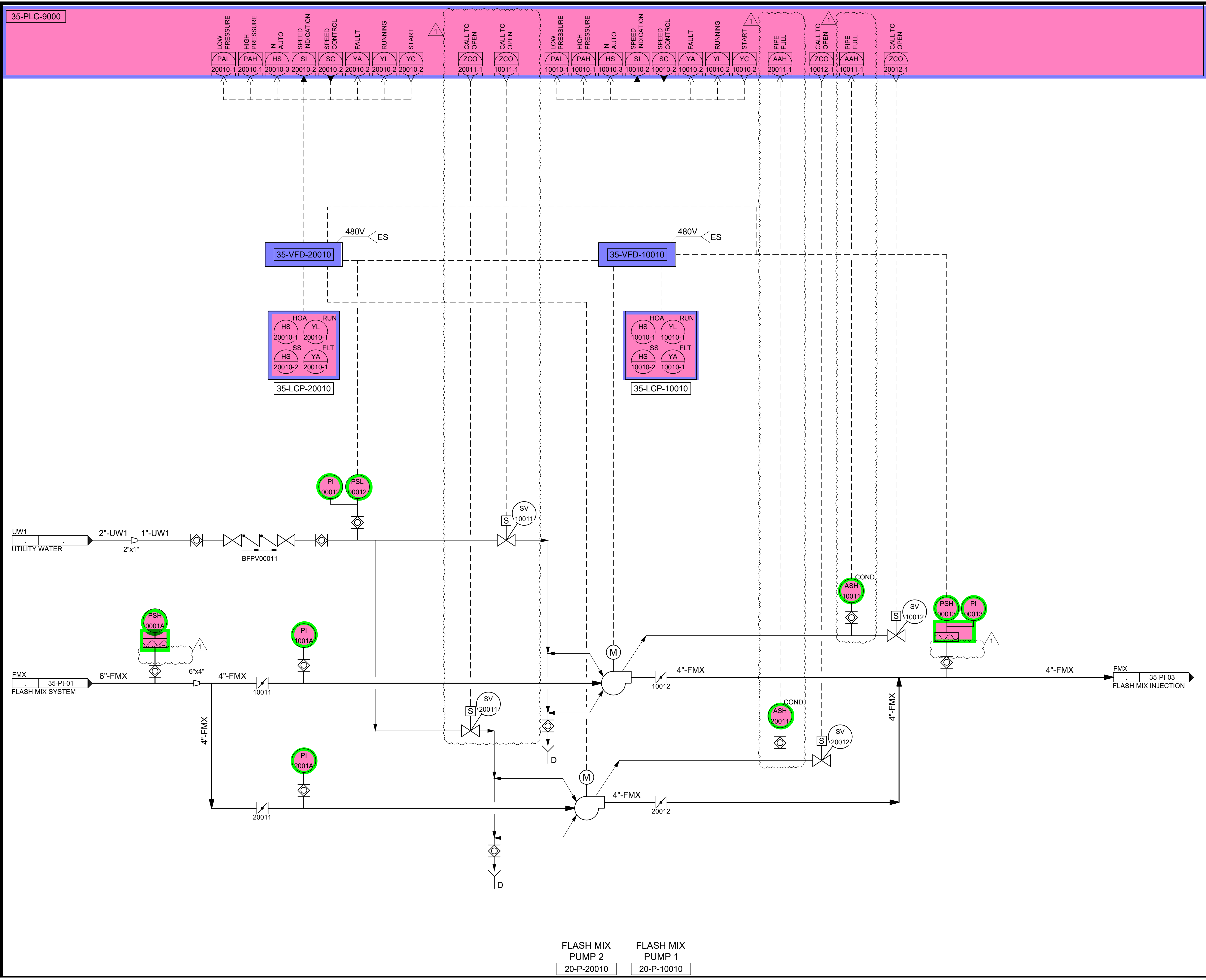

FLASH MIX PUMP 2
20-P-20010

FLASH MIX PUMP 1
20-P-10010

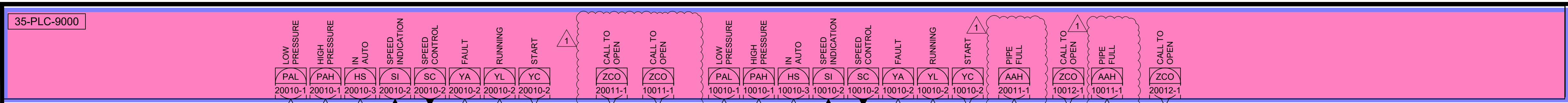

SALT LAKE CITY DEPARTMENT OF PUBLIC UTILITIES
CITY CREEK TREATMENT PLANT UPGRADES
BRIC PACKAGE
TREATMENT - FLASH MIX PUMP

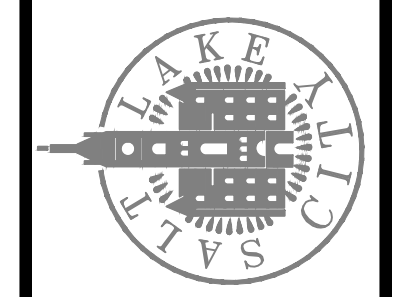

90% GMP

DRAWING NO.
35-PI-02

Brown and Caldwell

REVISIONS	
NO.	DATE
0	06/14/24
1	06/27/24

ISSUED FOR GUARANTEE MAXIMUM PRICE (GMP)
REVISED FOR GUARANTEE MAXIMUM PRICE (GMP)

DESIGNED BY:	AUTH. BY:	MADE BY:
BOTANI	ALAPIERRE	BO
ALAPIERRE	BO	BO
ALAPIERRE	BO	BO
ALAPIERRE	BO	BO

DESIGNED BY: BOTANI
DRAWN BY: ALAPIERRE
CHECKED BY: ALAPIERRE
APPROVED BY: BOTANI
DATE: JUNE 2024
EWO NO: ---
ACCOUNT NO: 512260079

SCALE: _____
VERIFY SCALE
BAR IS ONE INCH ON ORIGINAL DRAWING

35-PLC-9000

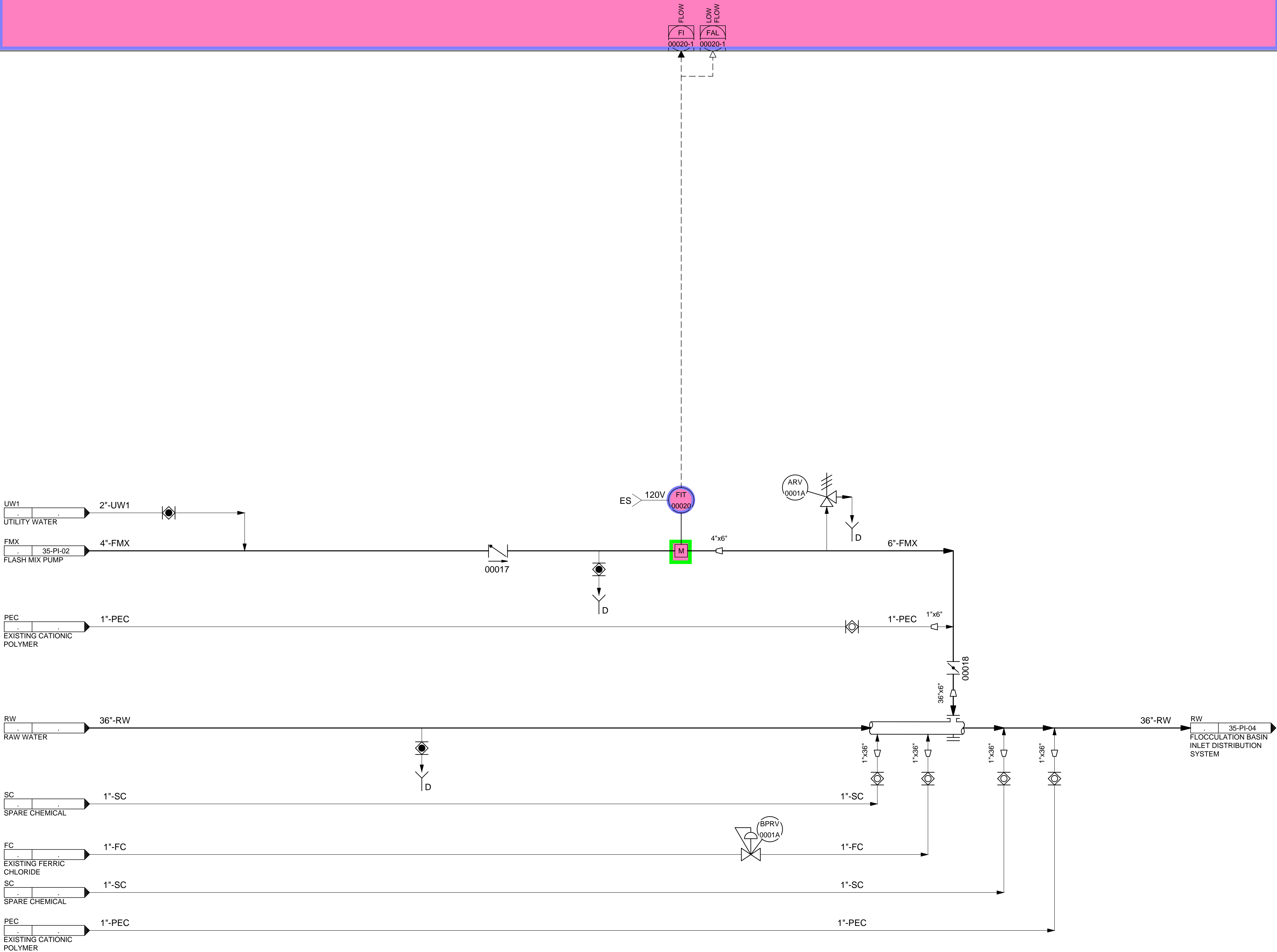

GENERAL NOTES:

- ALL SAMPLE DRAIN LINES ON THIS DRAWING SHALL BO TO THE TREATMENT RECYCLE PUMP STATION.

DESIGNED BY: BOTANI
 DRAWN BY: ALAPIERRE
 CHECKED BY: J.PAGENDARM
 APPROVED BY: BOTANI
 DATE: JUNE 2024
 EWO NO: ---
 ACCOUNT NO: 512260079

NO.	DATE	REVISIONS	MADE BY	AUTH. BY
0	06/14/24	ISSUED FOR GUARANTEE MAXIMUM PRICE (GMP)	BO	BO

SALT LAKE CITY DEPARTMENT OF PUBLIC UTILITIES
 CITY CREEK TREATMENT PLANT UPGRADES
 BRIC PACKAGE
TREATMENT - FLASH MIX INJECTION

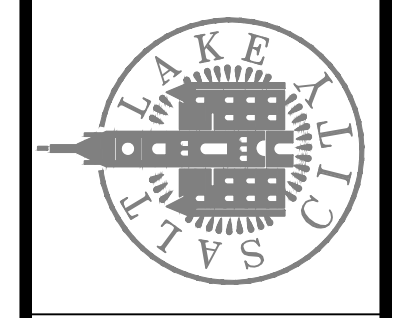

90% GMP

DRAWING NO.
35-PI-03

Brown and Caldwell

C:\Users\alapierre\AppData\Local\Autodesk\AutoCAD Plant_3D\Collaboration\Coche\153020-SLICDPL_City_Creek_WTP-V2021\PID_DWG\35-PI-03.dwg Jun 12, 2024 -- 3:46pm

C:\Users\elapierre\AppData\Local\Autodesk\AutoCAD Plant 3D\Collaboration\Cache\153020-SICDPIU_City_Creek_WTP-V2021\PID_DWG\35-PI-04.dwg Jun. 12, 2024 - 9:10pm

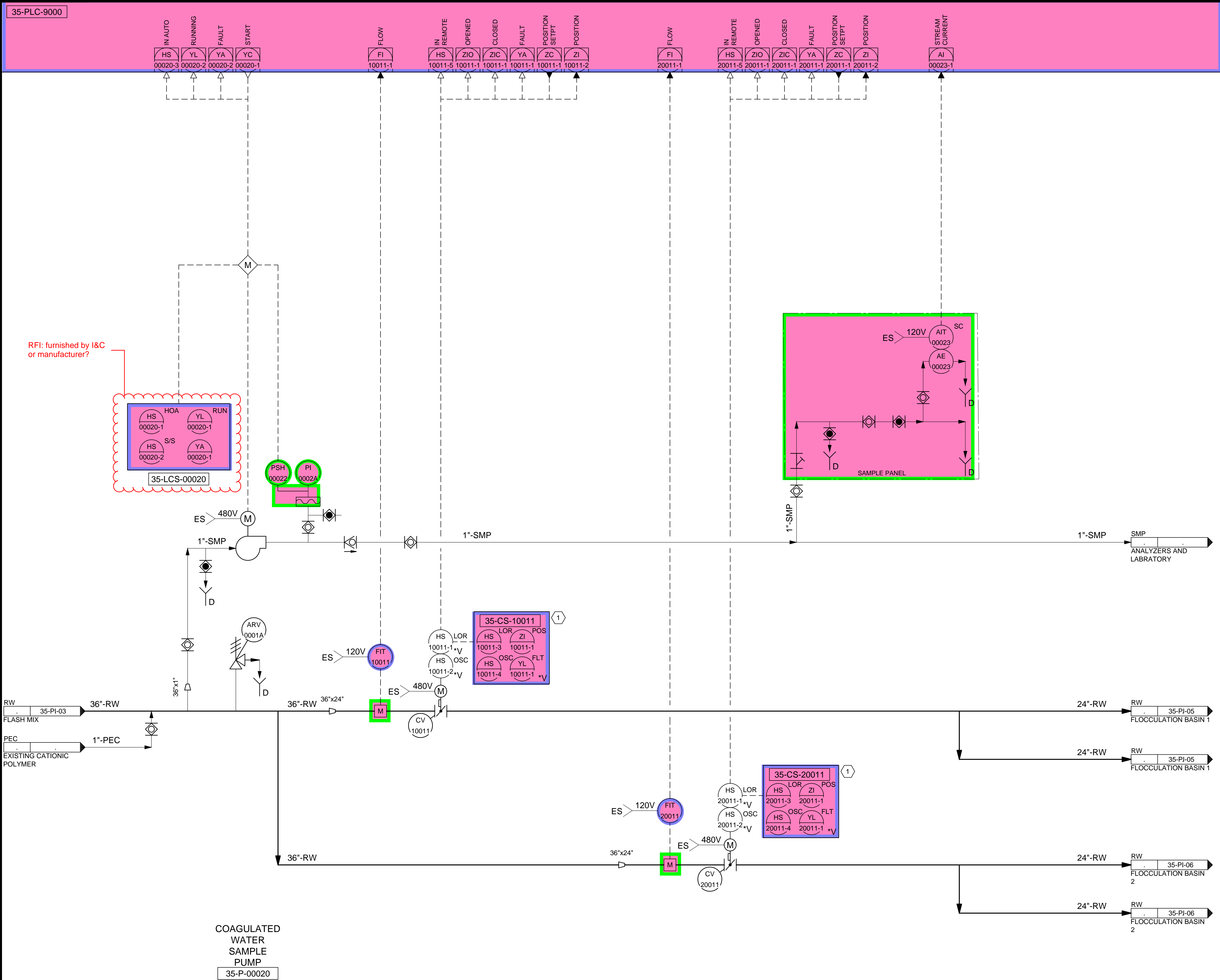

RFI: furnished by I&C or manufacturer?

KEYNOTES:

- 1 PROVIDE A REMOTE CONTROL STATION FOR THE ACTUATOR TO BE MOUNTED 48" ABOVE THE FLOOR ELEVATION. REMOTE CONTROL STATION SHALL BE RATED FOR NEMA 4X AND HAVE THE SAME FUNCTIONALITY AS THE ACTUATOR FACEPLATE.

NO.	DATE	REVISIONS
0	06/14/24	ISSUED FOR GUARANTEE MAXIMUM PRICE (GMP)

DESIGNED BY: BLOTANI
 DRAWN BY: ALAPIERRE
 CHECKED BY: JFAGENDARM
 APPROVED BY: BLOTANI
 DATE: JUNE 2024
 EWO NO: --
 ACCOUNT NO: 512260079

SCALE: _____

VERIFY SCALE
 BAR IS ONE INCH ON ORIGINAL DRAWING

SALT LAKE CITY DEPARTMENT OF PUBLIC UTILITIES
 CITY CREEK TREATMENT PLANT UPGRADES
 BRIC PACKAGE
**TREATMENT - FLOCCULATION
 BASIN INLET CHANNEL**

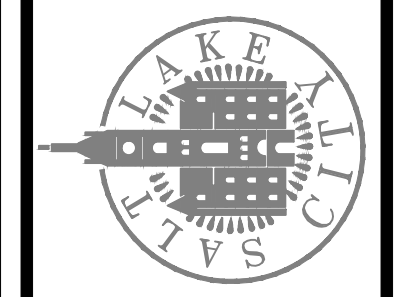

90% GMP

DRAWING NO.
35-PI-04

Brown and Caldwell

C:\Users\alapiere\AppData\Local\Autodesk\AutoCAD Plant_3D\CollaborationCache\153020-SLCP\PL_City_Creek_WTP-V2021\PID_DWG\35-PI-05.dwg Jun 12, 2024 -- 3:51pm

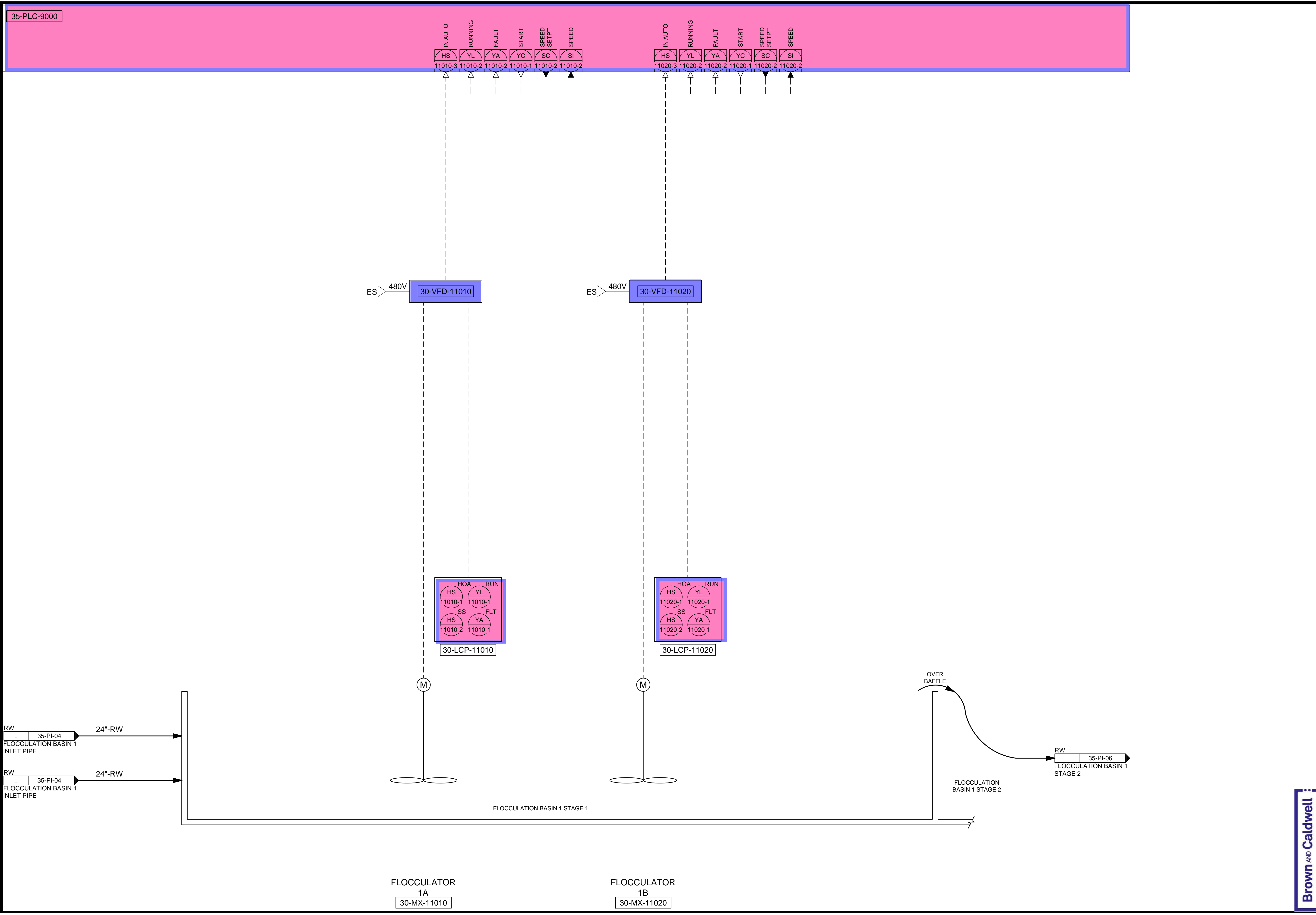

35-PLC-9000

FLOCCULATOR
1A
30-MX-11010

FLOCCULATOR
1B
30-MX-11020

SALT LAKE CITY DEPARTMENT OF PUBLIC UTILITIES
CITY CREEK TREATMENT PLANT UPGRADES
BRIC PACKAGE
**TREATMENT - FLOCCULATION
BASIN 1, STAGE 1**

90% GMP

DRAWING NO.
35-PI-05

Brown and Caldwell

REVISIONS	
NO.	DATE
0	06/14/24 ISSUED FOR GUARANTEE MAXIMUM PRICE (GMP)

DESIGNED BY: BOTANI	AUTH. BY: BO	MADE BY: BO
DRAWN BY: ALAPIERE	BY: BO	BY: BO
CHECKED BY: J.PAGENDARM		
APPROVED BY: BOTANI		
DATE: JUNE 2024		
EWO NO: --		
ACCOUNT NO: 512260079		

SCALE: _____
VERIFY SCALE
BAR IS ONE INCH ON ORIGINAL DRAWING

C:\Users\alapiere\AppData\Local\Autodesk\AutoCAD Plant 3D\Collaboration\AutoCAD Plant 3D\Collaboration\CACHE\153020-SLICDPL_City_Creek_WTP-v2021\PID_DWG\35-PI-06.dwg Jun 12, 2024 - 3:52pm

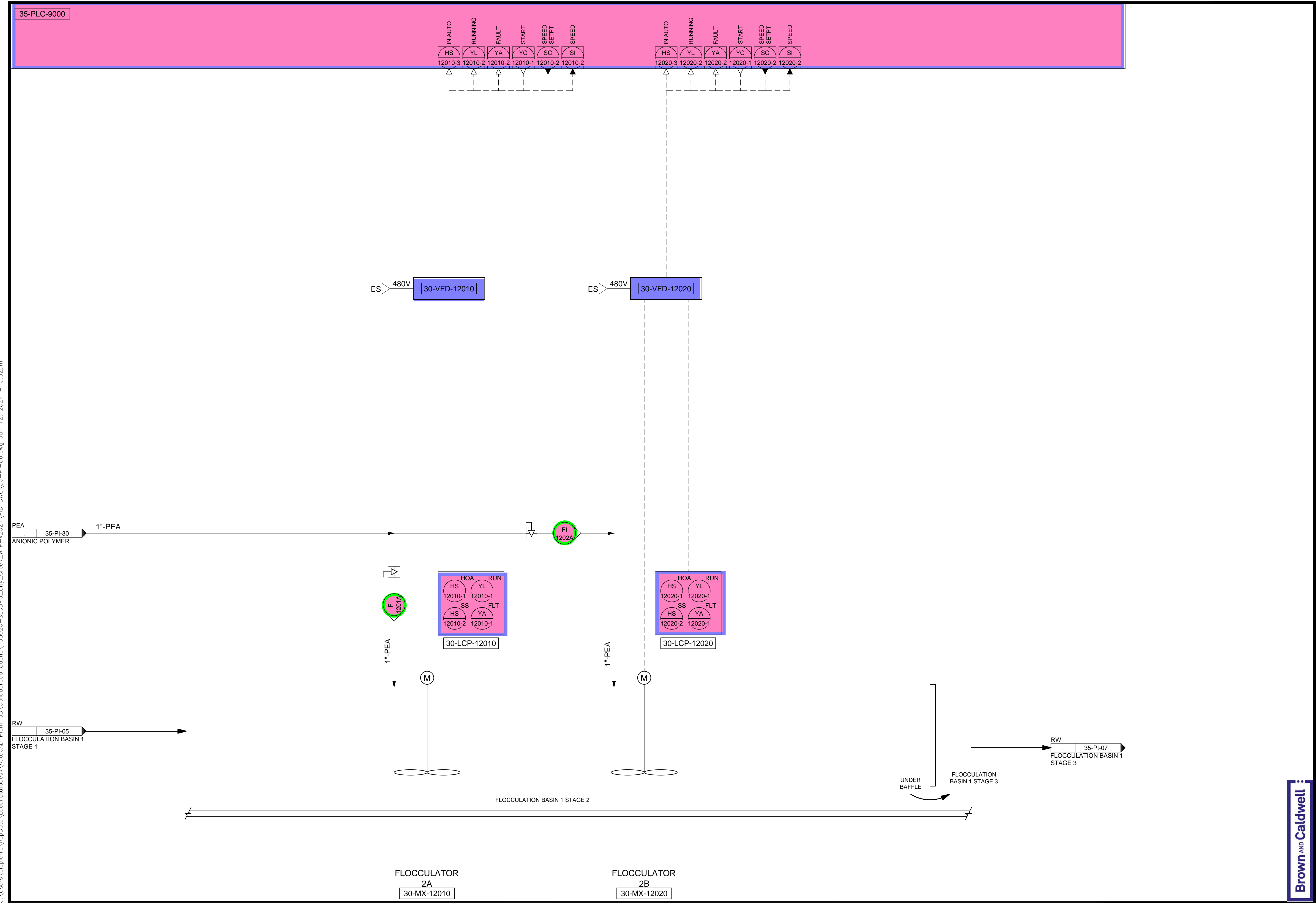

PEA ANIONIC POLYMER 35-PI-30 1"-PEA

RW 35-PI-05 FLOCCULATION BASIN 1 STAGE 1

DESIGNED BY: BOTANI
 DRAWN BY: ALAPIERE
 CHECKED BY: J.PAGENDARM
 APPROVED BY: BOTANI
 DATE: JUNE 2024
 EWO NO: 512260079
 ACCOUNT NO: 512260079

AUTH BY: BO
 MADE BY: BO

NO. DATE

0	06/14/24	ISSUED FOR GUARANTEE MAXIMUM PRICE (GMP)
---	----------	--

REVISIONS

SALT LAKE CITY DEPARTMENT OF PUBLIC UTILITIES
 CITY CREEK TREATMENT PLANT UPGRADES
 BRIC PACKAGE
**TREATMENT - FLOCCULATION
 BASIN 1, STAGE 2**

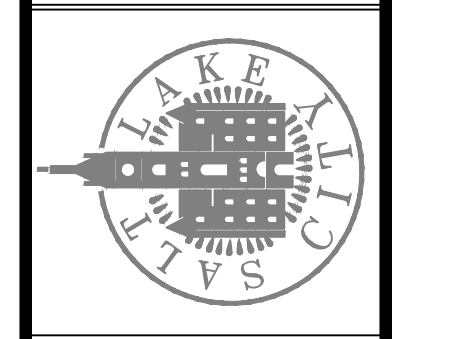

Brown and Caldwell

90% GMP

DRAWING NO.
35-PI-06

SCALE:
VERIFY SCALE
 BAR IS ONE INCH ON ORIGINAL DRAWING

C:\Users\alapiere\AppData\Local\Autodesk\AutoCAD Plant_3D\CollaborationCache\153020-SLICDPL_City_Creek_WTP-v2021\PID_DWG\35-PI-07.dwg Jun 12, 2024 -- 4:11pm

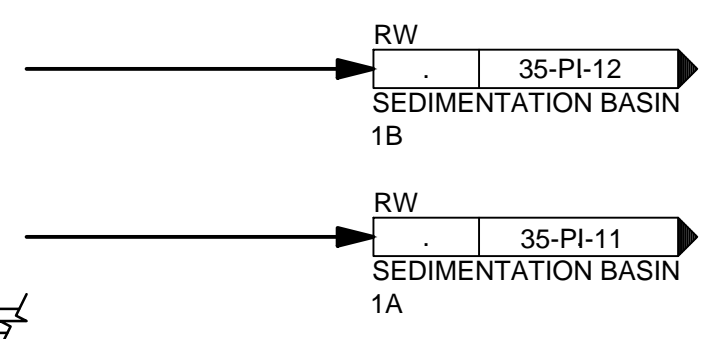
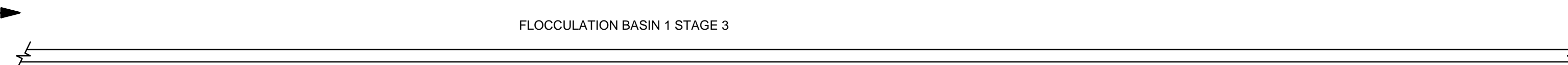
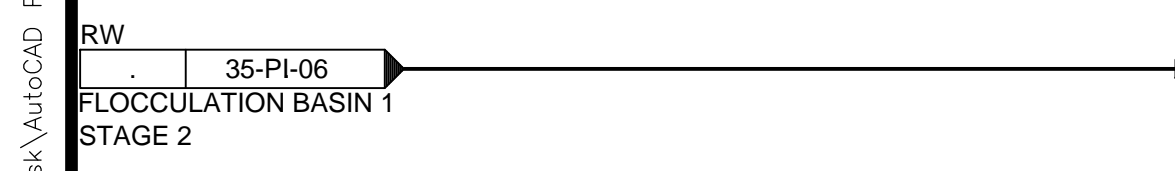
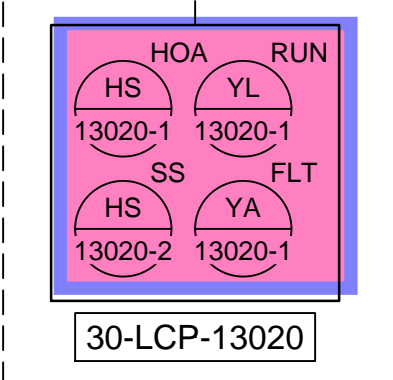
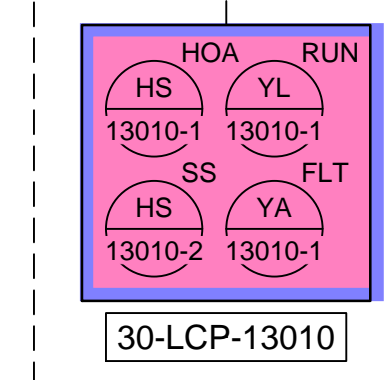
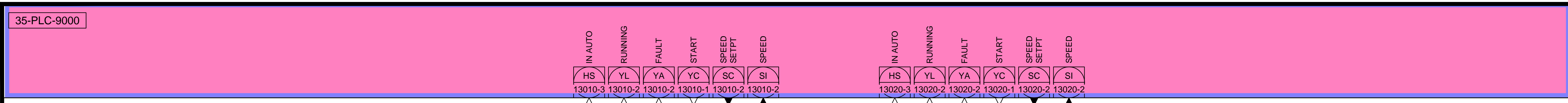

FLOCCULATOR
3A
30-MX-13010

FLOCCULATOR
3B
30-MX-13020

Brown and Caldwell

SALT LAKE CITY DEPARTMENT OF PUBLIC UTILITIES
CITY CREEK TREATMENT PLANT UPGRADES
BRIC PACKAGE
**TREATMENT - FLOCCULATION
BASIN 1, STAGE 3**

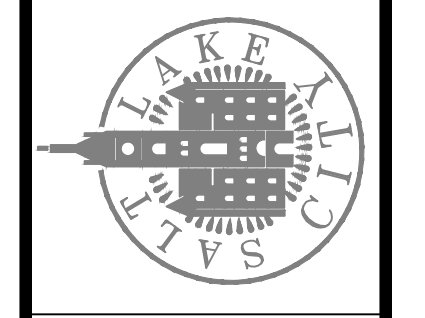

90% GMP

DRAWING NO.
35-PI-07

REVISIONS

NO.	DATE	ISSUED FOR	GUARANTEE	MAXIMUM PRICE (GMP)
0	06/14/24	ISSUED FOR	GUARANTEE	MAXIMUM PRICE (GMP)

DESIGNED BY: BOTANI
DRAWN BY: ALAPIERE
CHECKED BY: J.PAGENDARM
APPROVED BY: BOTANI
DATE: JUNE 2024
EWO NO: 512260079
ACCOUNT NO: 512260079

SCALE:

VERIFY SCALE
BAR IS ONE INCH ON ORIGINAL DRAWING

35-PLC-9000

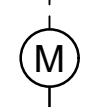
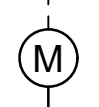
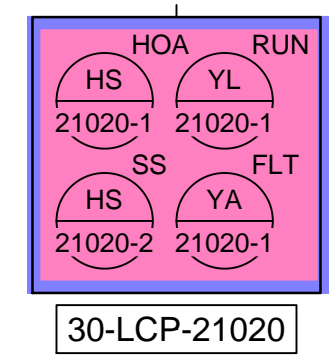
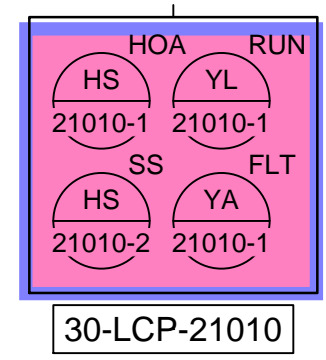
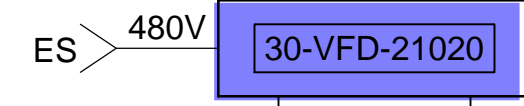
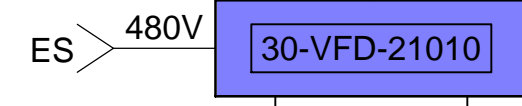

FLOCCULATION BASIN 2 STAGE 1

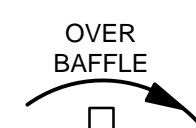

FLOCCULATION BASIN 2 STAGE 2

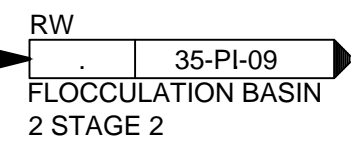
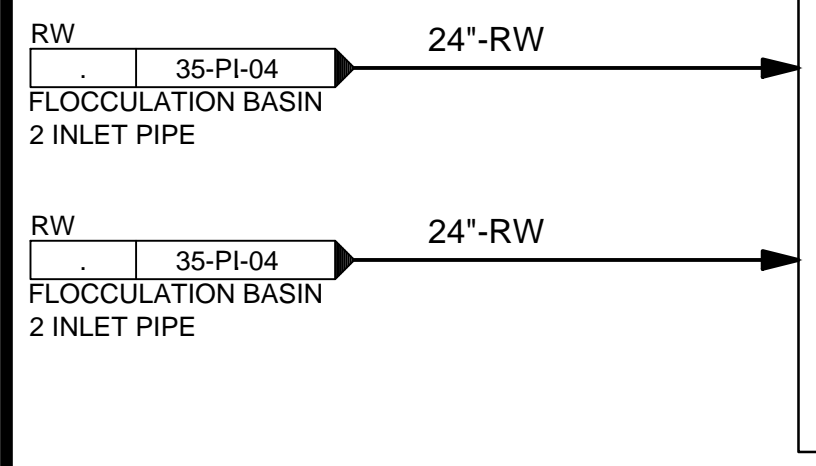

FLOCCULATOR
1A
30-MX-21010

FLOCCULATOR
1B
30-MX-21020

REVISIONS	
NO.	DATE
0	06/14/24
ISSUED FOR GUARANTEE MAXIMUM PRICE (GMP)	

SALT LAKE CITY DEPARTMENT OF PUBLIC UTILITIES
CITY CREEK TREATMENT PLANT UPGRADES
BRIC PACKAGE
**TREATMENT - FLOCCULATION
BASIN 2, STAGE 1**

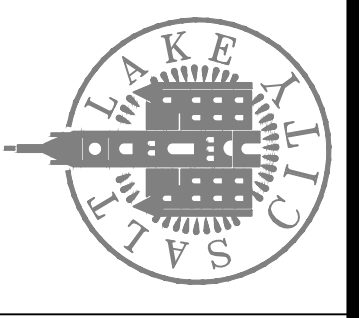

90% GMP

DRAWING NO.
35-PI-08

Brown and Caldwell

DESIGNED BY: BOTANI
DRAWN BY: ALAPIERRE
CHECKED BY: J.PAGENDARM
APPROVED BY: BOTANI
DATE: JUNE 2024
EWO NO: ---
ACCOUNT NO: 512260079

SCALE: _____

VERIFY SCALE
BAR IS ONE INCH ON ORIGINAL DRAWING

C:\Users\alapiere\AppData\Local\Autodesk\AutoCAD Plant_3D\CollaborationCache\153020-SLICDPL_City_Creek_WTP-v2021\PID_DWG\35-PI-09.dwg Jun 12, 2024 -- 4:15pm

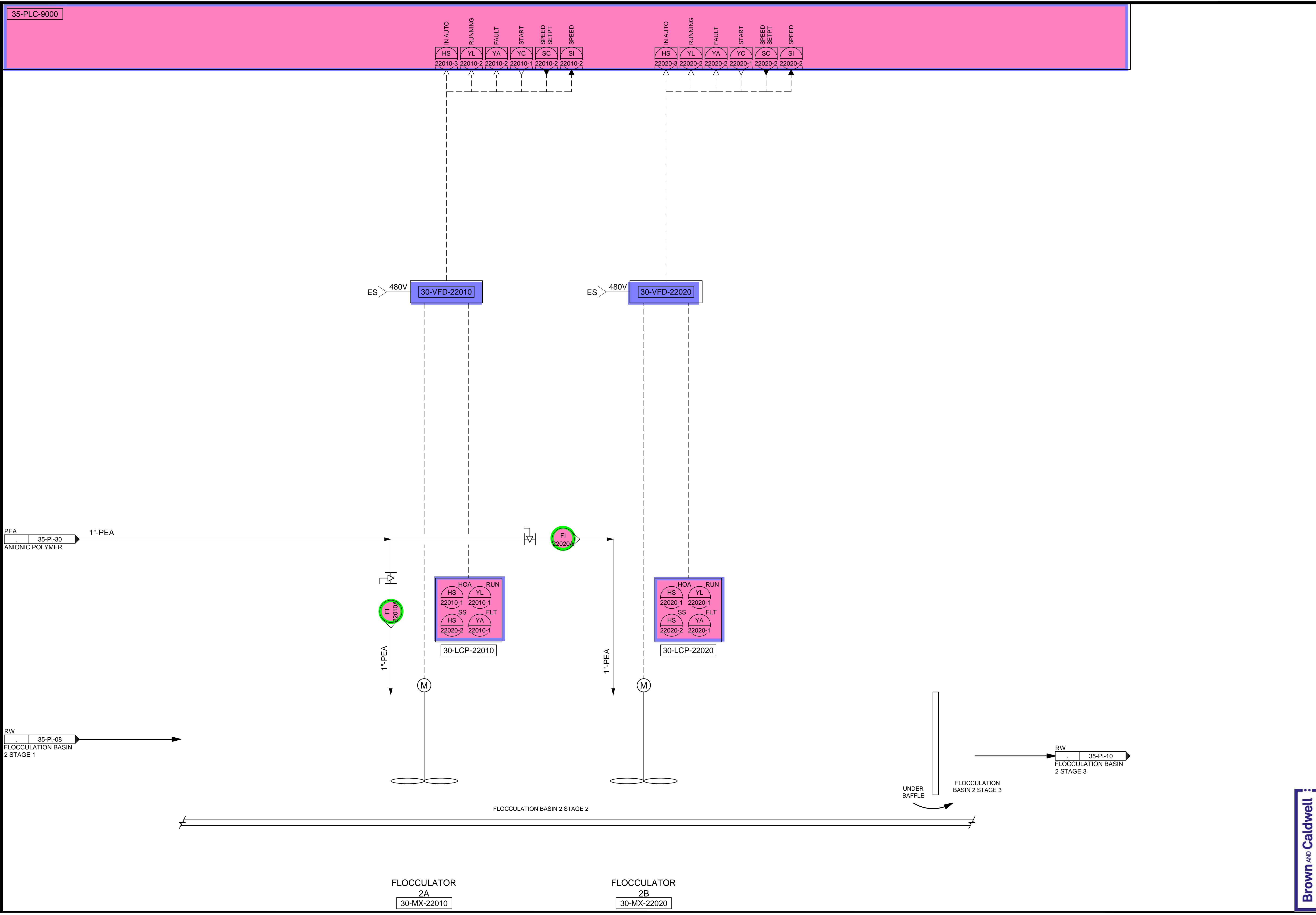

35-PLC-9000

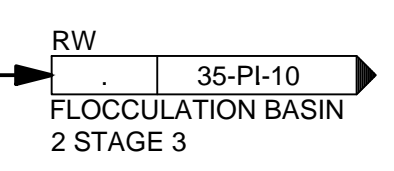
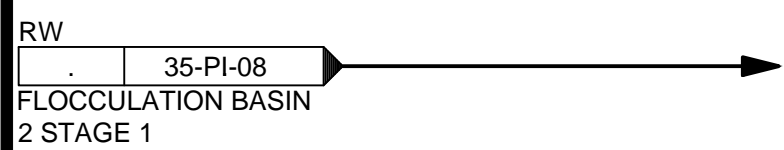
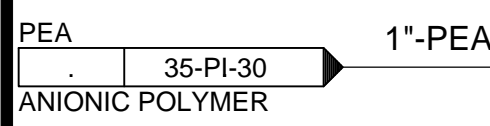
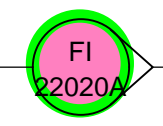
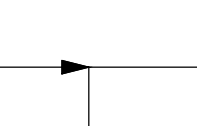
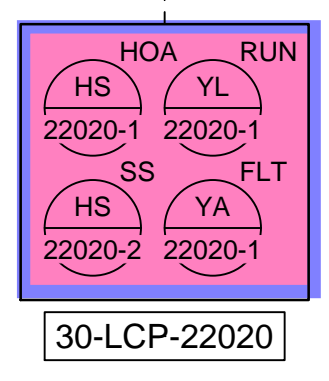
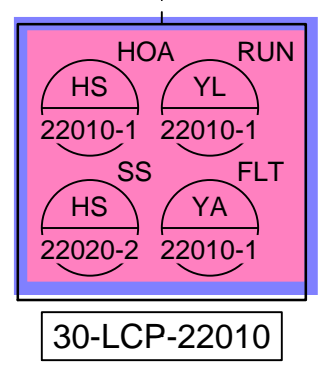
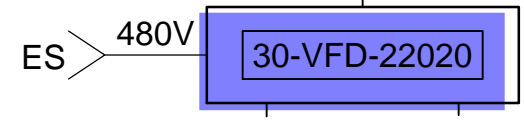
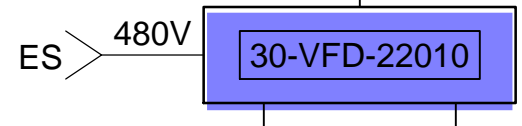
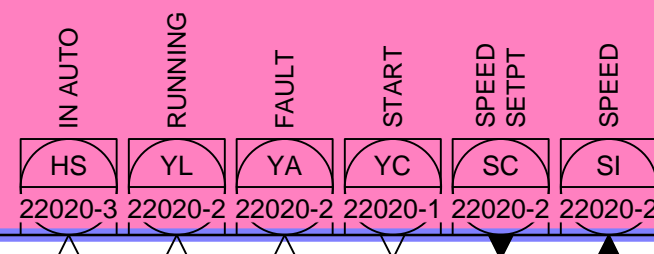
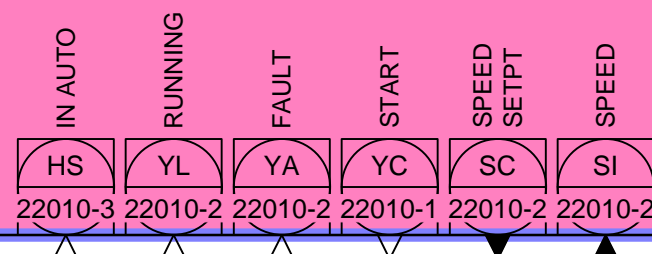

FLOCCULATOR
2A
30-MX-22010

FLOCCULATOR
2B
30-MX-22020

REVISIONS	
NO.	DATE
0	06/14/24

ISSUED FOR GUARANTEE MAXIMUM PRICE (GMP)

SALT LAKE CITY DEPARTMENT OF PUBLIC UTILITIES
CITY CREEK TREATMENT PLANT UPGRADES
BRIC PACKAGE
**TREATMENT - FLOCCULATION
BASIN 2, STAGE 2**

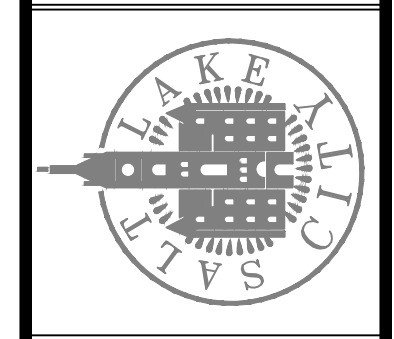

90% GMP

DRAWING NO.
35-PI-09

Brown and Caldwell

DESIGNED BY: BOTANI
DRAWN BY: ALAPIERE
CHECKED BY: J.PAGENDARM
APPROVED BY: BOTANI
DATE: JUNE 2024
EWO NO: 512260079
ACCOUNT NO: 512260079

SCALE: _____

VERIFY SCALE
BAR IS ONE INCH ON ORIGINAL DRAWING

C:\Users\alopierre\AppData\Local\Autodesk\AutoCAD Plant_3D\CollaborationCache\153020-SLICDPL_City_Creek_WTP-v2021\PID_DWG\35-PI-10.dwg Jun 12, 2024 -- 4:17pm

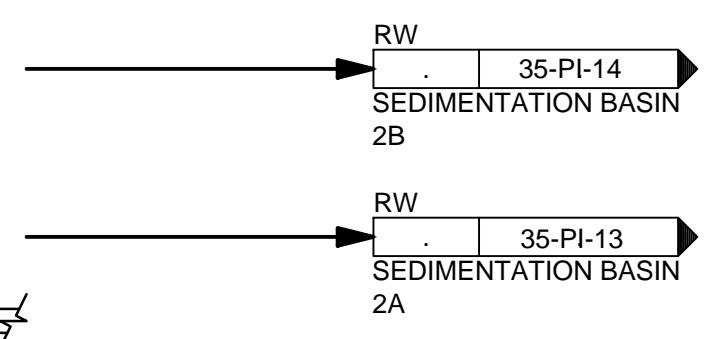
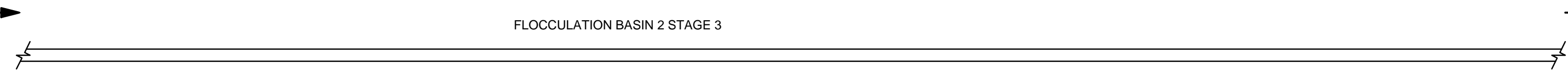
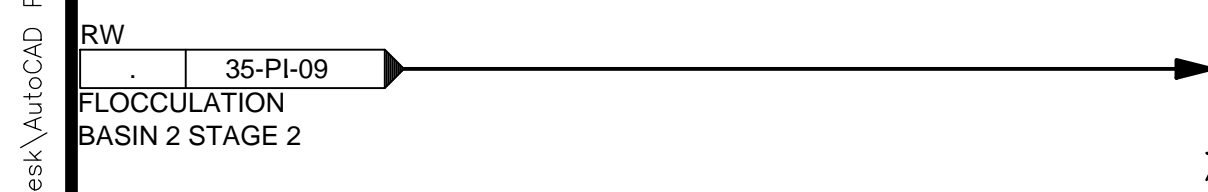
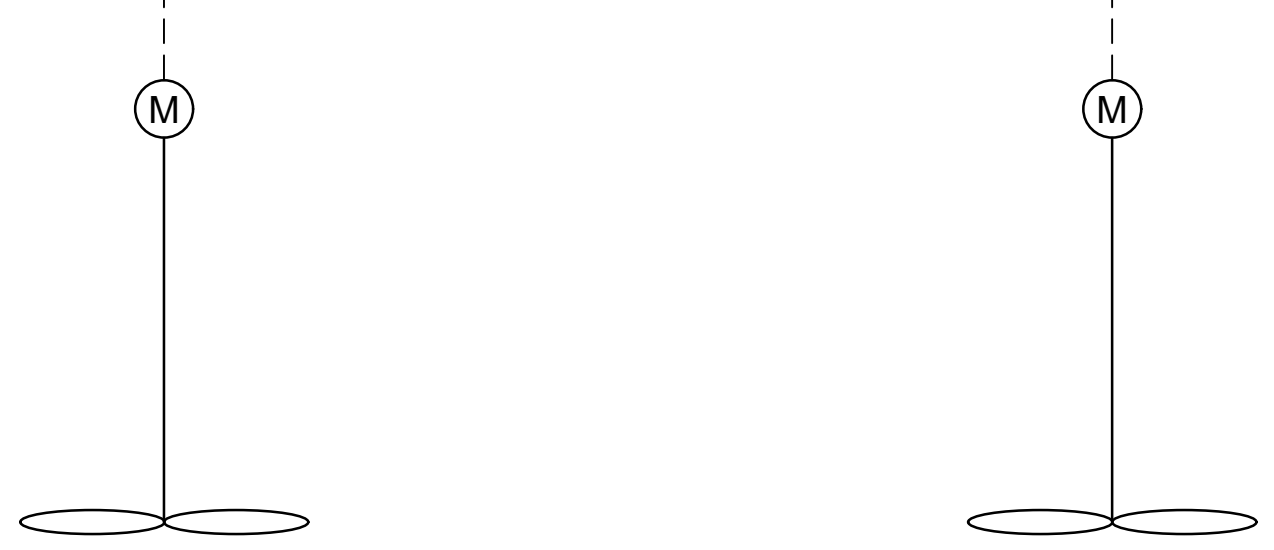
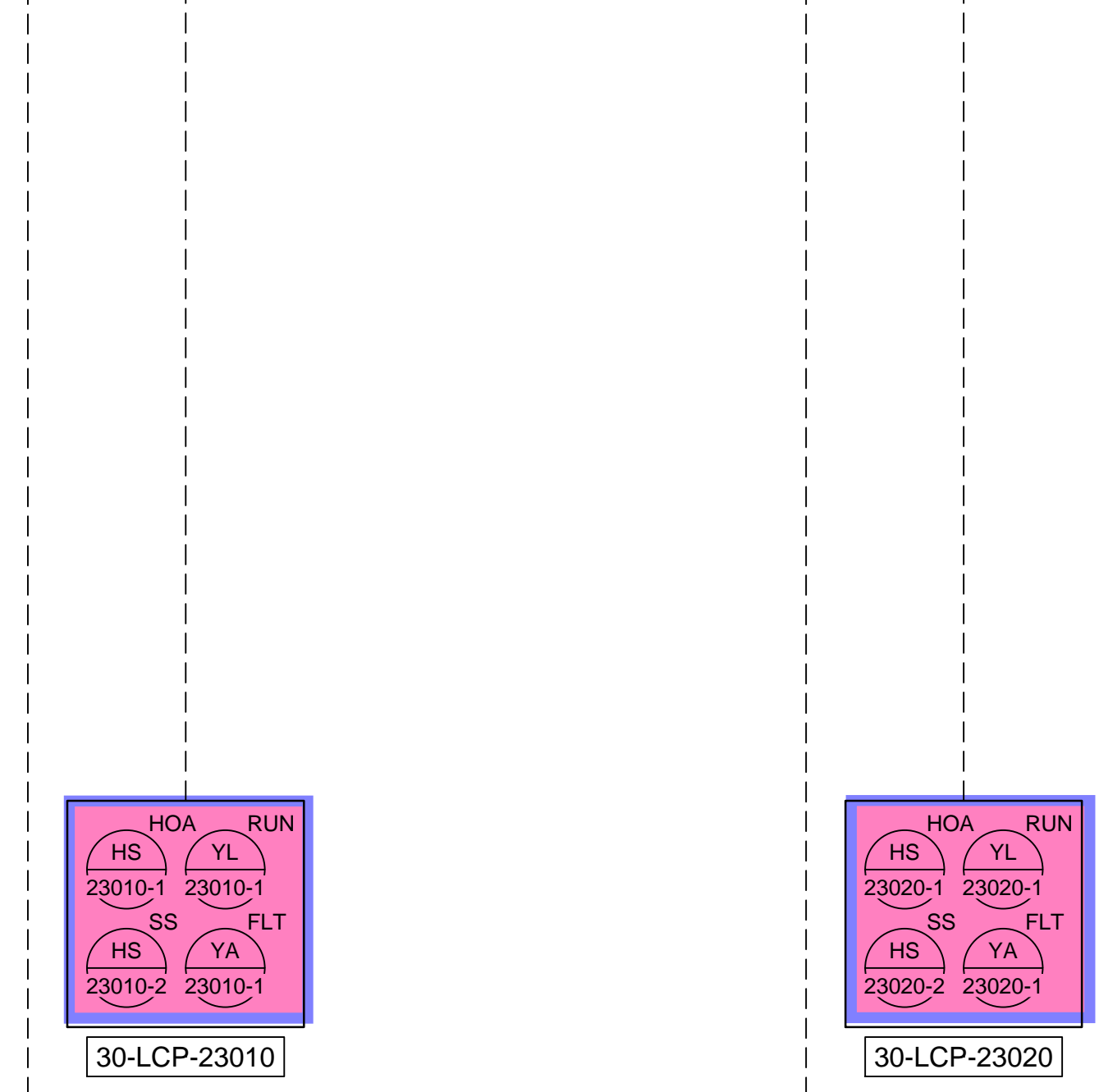
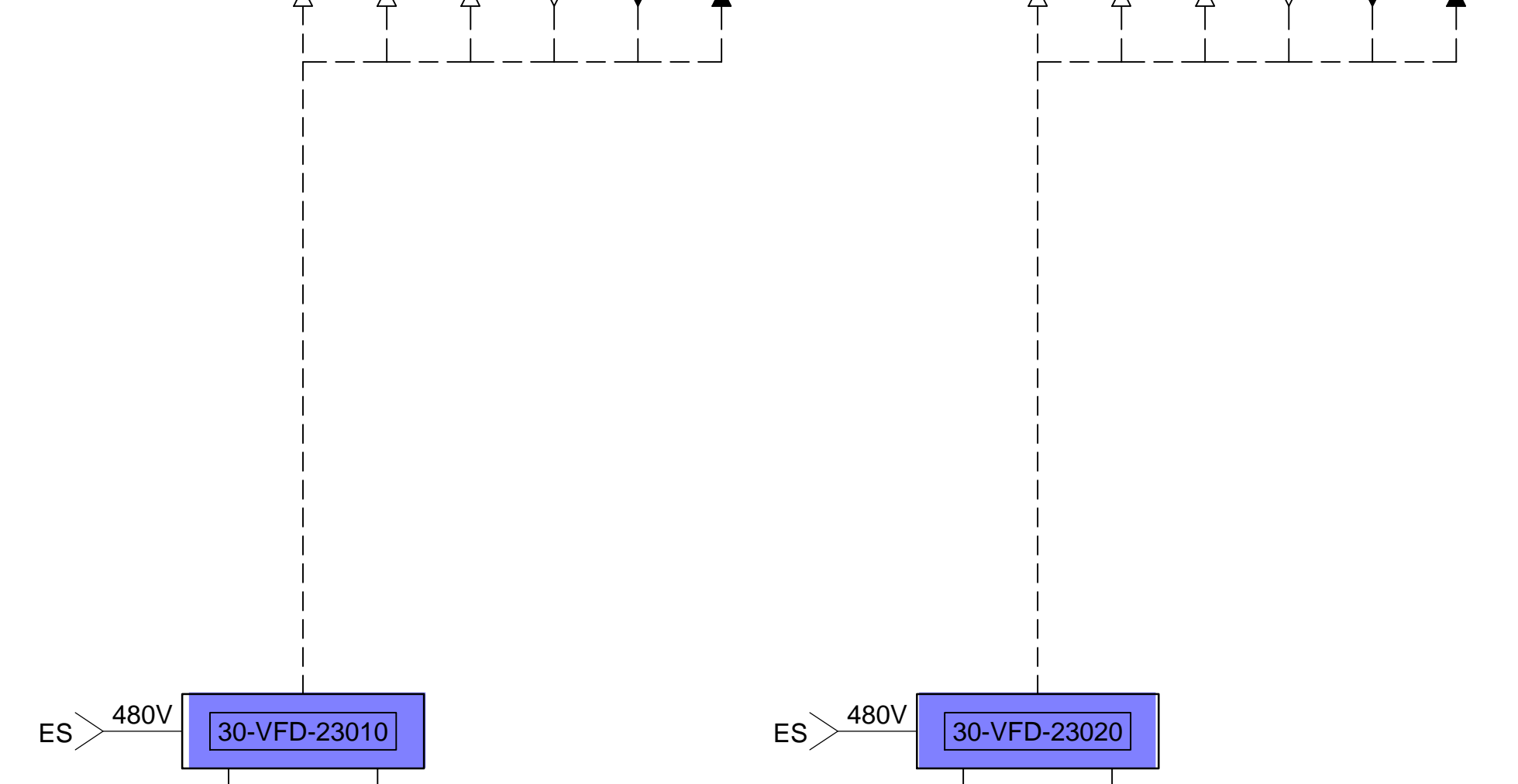
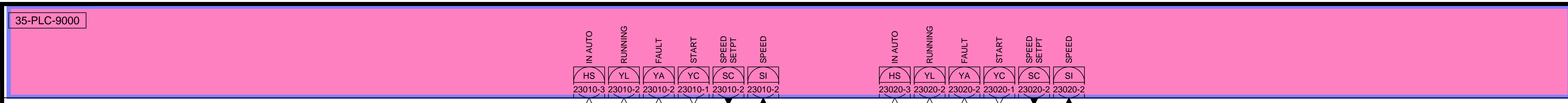

FLOCCULATOR 3A
30-MX-23010

FLOCCULATOR 3B
30-MX-23020

REVISIONS	
NO.	DATE
0	06/14/24 ISSUED FOR GUARANTEE MAXIMUM PRICE (GMP)

SALT LAKE CITY DEPARTMENT OF PUBLIC UTILITIES
 CITY CREEK TREATMENT PLANT UPGRADES
 BRIC PACKAGE
**TREATMENT - FLOCCULATION
 BASIN 2, STAGE 3**

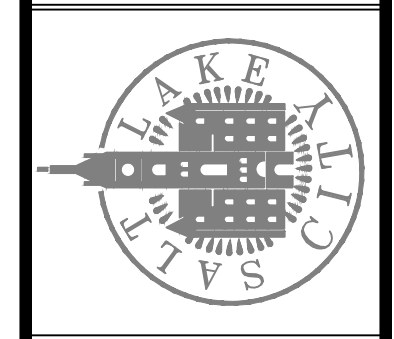

90% GMP

DRAWING NO.
35-PI-10

Brown and Caldwell

DESIGNED BY: BOTANI
 DRAWN BY: ALAPIERRE
 CHECKED BY: J.PAGENDARM
 APPROVED BY: BOTANI
 DATE: JUNE 2024
 EWO NO: ---
 ACCOUNT NO: 512260079

SCALE:
 VERIFY SCALE
 BAR IS ONE INCH ON ORIGINAL DRAWING

C:\Users\alapiere\AppData\Local\Autodesk\AutoCAD Plant_3D\CollaborationCache\153020-SLDCPPL_City_Creek_WTP-V2021\PID_DWG\35-PI-11.dwg Jun 21, 2024 -- 3:16pm

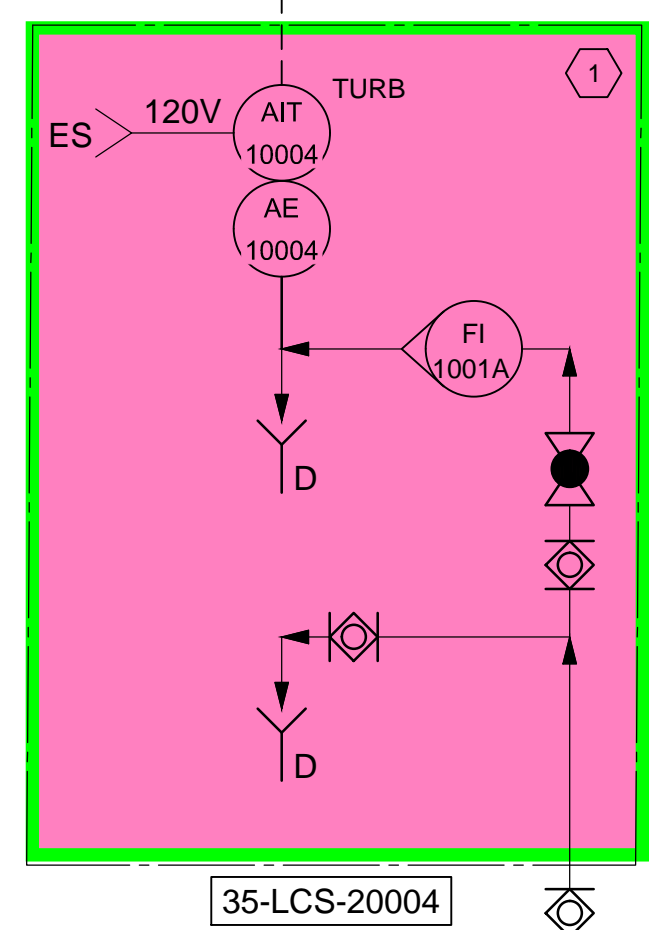
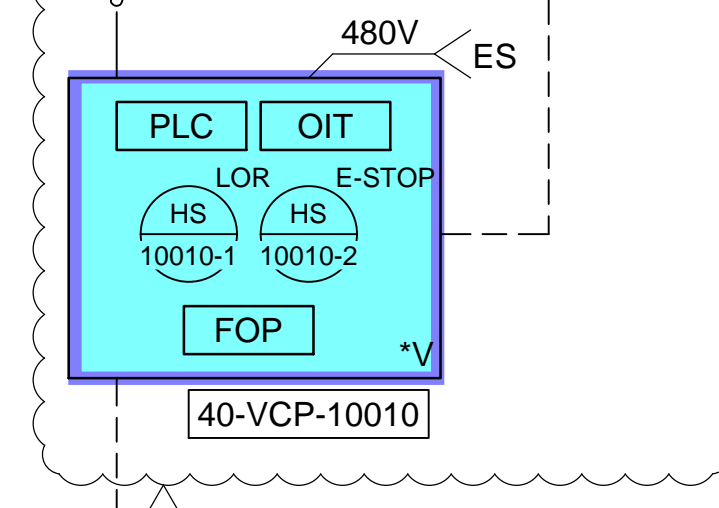
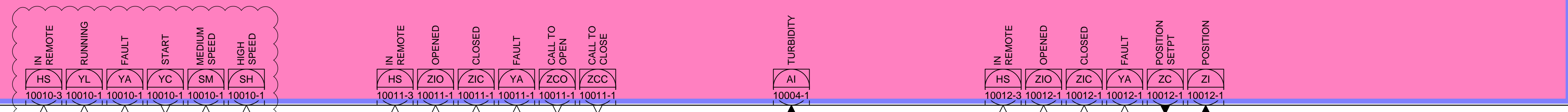
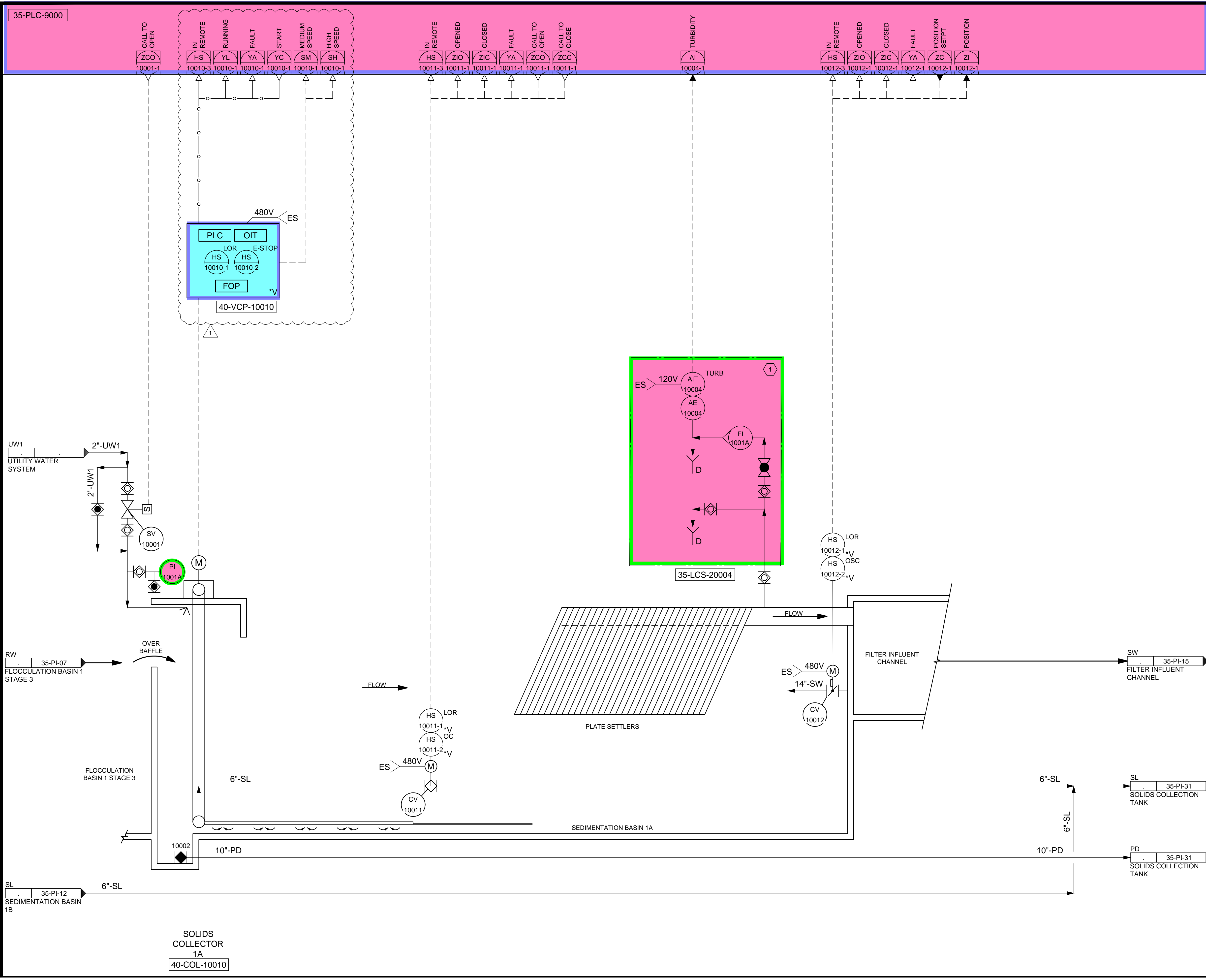

KEYNOTES:

1 SAMPLE PANEL TO BE LOCATED IN THE FILTER GALLERY

DESIGNED BY: BOTANI
 DRAWN BY: ALAPIERE
 CHECKED BY: ALPAGENDARR
 APPROVED BY: BOTANI
 DATE: JUNE 2024
 EMO NO: 512260079
 ACCOUNT NO: 512260079

SCALE: _____

VERIFY SCALE
 BAR IS ONE INCH ON ORIGINAL DRAWING

NO.	DATE	REVISIONS	MADE BY	AUTH. BY
0	06/14/24	ISSUED FOR GUARANTEE MAXIMUM PRICE (GMP)	BO	BO
1	06/27/24	REVISED FOR GUARANTEE MAXIMUM PRICE (GMP)	BO	BO

SALT LAKE CITY DEPARTMENT OF PUBLIC UTILITIES
 CITY CREEK TREATMENT PLANT UPGRADES
 BRIC PACKAGE
TREATMENT - SEDIMENTATION BASIN 1A

90% GMP

DRAWING NO.
35-PI-11

Brown and Caldwell

C:\Users\alapiere\AppData\Local\Autodesk\AutoCAD Plant_3D\CollaborationCache\153020-SUCOPL City_Creek_WTP-V2021\PID_DWG\35-PI-12.dwg Jun 21, 2024 -- 2:32pm

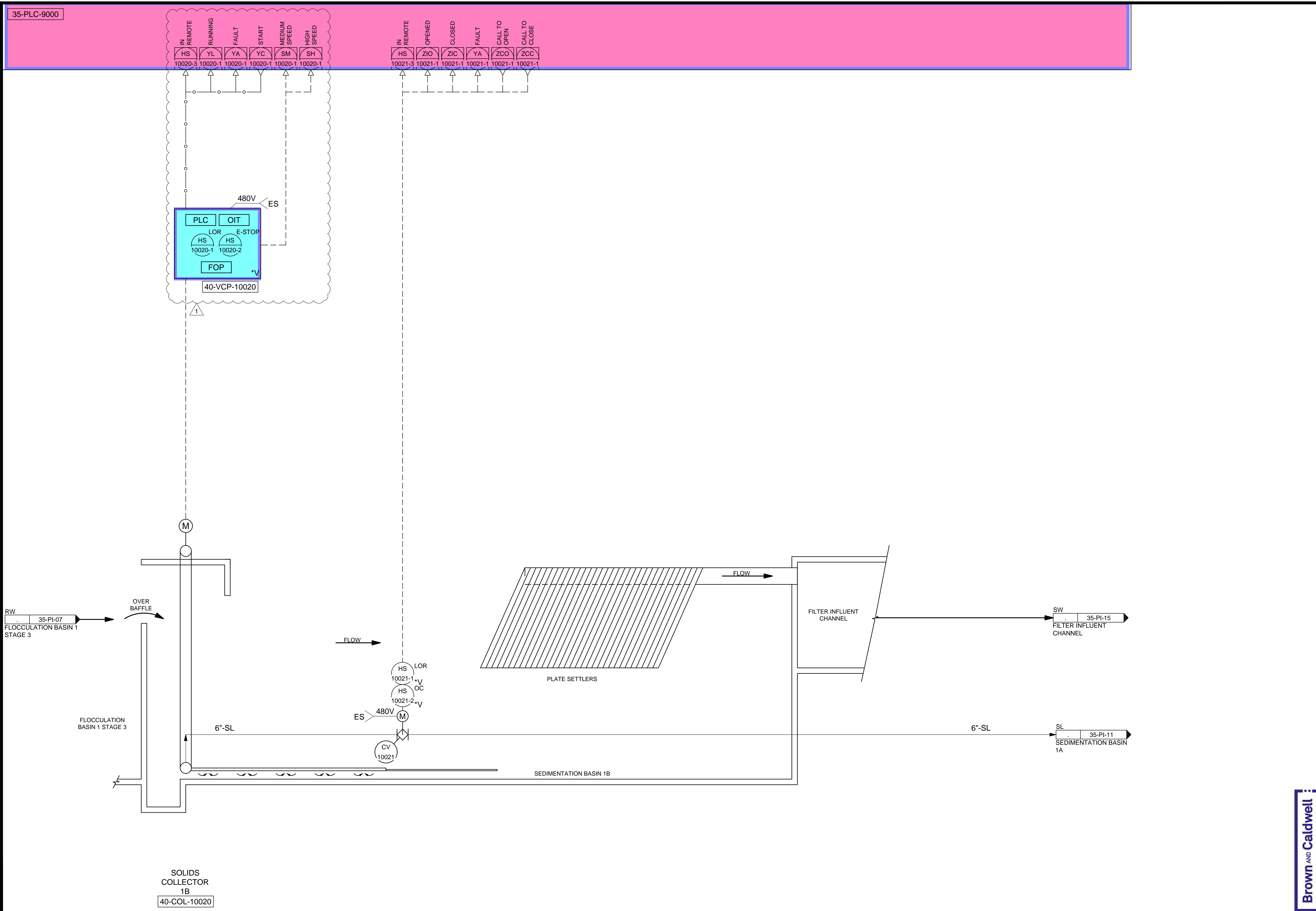

SALT LAKE CITY DEPARTMENT OF PUBLIC UTILITIES
CITY CREEK TREATMENT PLANT UPGRADES
BRIC PACKAGE

**TREATMENT - SEDIMENTATION
BASIN 1B**

90% GMP

DRAWING NO.
35-PI-12

REVISIONS	
NO.	DATE
0	06/14/24
1	06/27/24

DESIGNED BY: BOTANI	AUTH. BY: BO
DRAWN BY: ALAPIERE	MADE BY: BO
CHECKED BY: ALPAGENDARM	BY: BO
APPROVED BY: BOTANI	BY: BO
DATE: JUNE 2024	
EWO NO: ---	
ACCOUNT NO: 512260079	

SCALE: _____

VERIFY SCALE
BAR IS ONE INCH ON ORIGINAL DRAWING

Brown and Caldwell

C:\Users\alapiere\AppData\Local\Autodesk\AutoCAD Plant 3D\CollaborationCache\153020-SLDCPPL_City_Creek_WTP-V2021\PID_DWG\35-PI-13.dwg Jun 21, 2024 -- 3:18pm

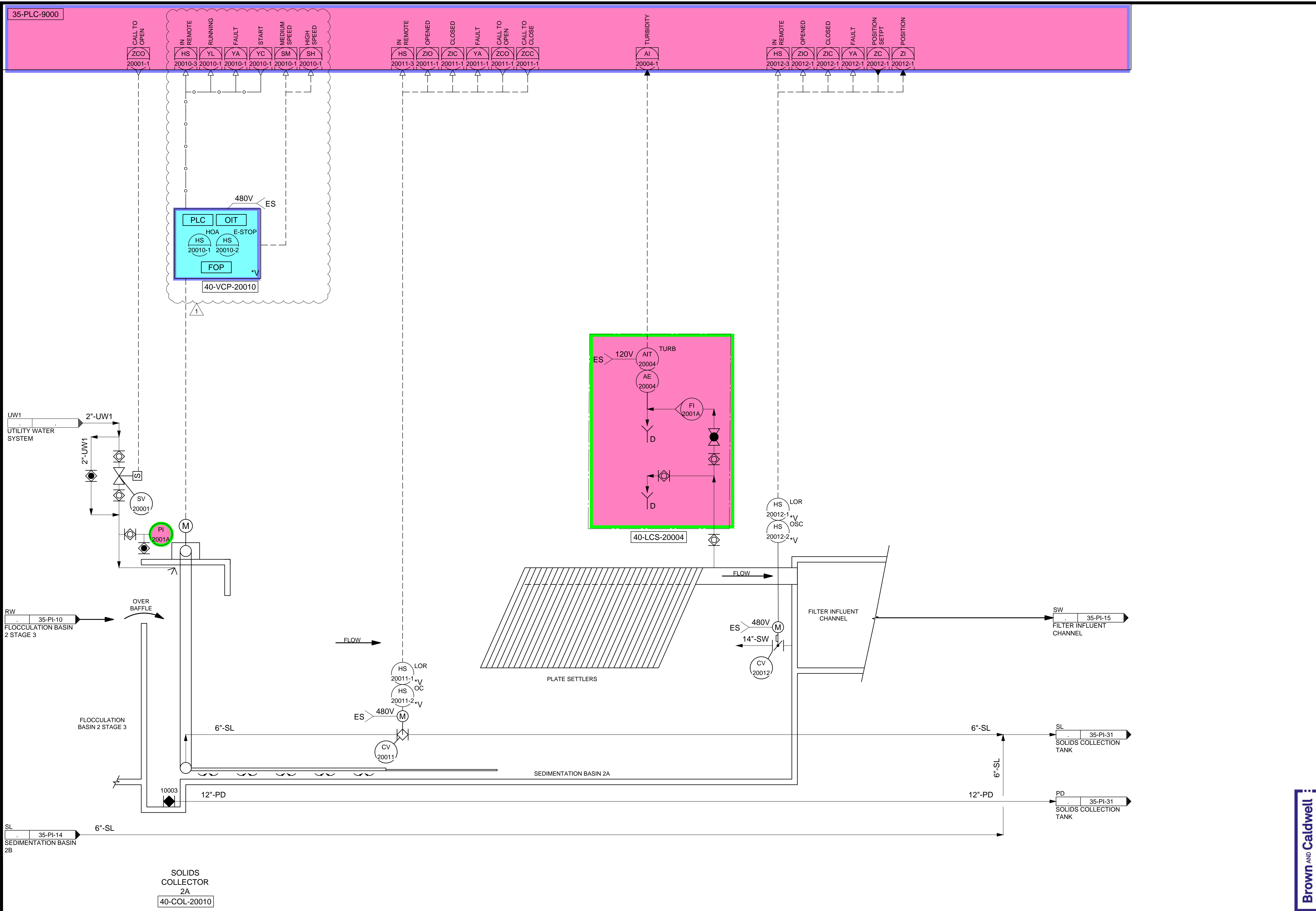

35-PLC-9000

CALL TO OPEN ZCO 20001-1	IN REMOTE HS 20010-3	RUNNING YL 20010-1	FAULT YA 20010-1	START YC 20010-1	MEDIUM SPEED SM 20010-1	HIGH SPEED SH 20010-1	IN REMOTE HS 20011-3	OPENED ZIO 20011-1	CLOSED ZIC 20011-1	FAULT YA 20011-1	CALL TO OPEN ZCO 20011-1	CALL TO CLOSE ZCC 20011-1	TURBIDITY AI 20004-1	IN REMOTE HS 20012-3	OPENED ZIO 20012-1	CLOSED ZIC 20012-1	FAULT YA 20012-1	POSITION SETPT ZC 20012-1	POSITION ZI 20012-1
--------------------------------	----------------------------	--------------------------	------------------------	------------------------	-------------------------------	-----------------------------	----------------------------	--------------------------	--------------------------	------------------------	--------------------------------	---------------------------------	----------------------------	----------------------------	--------------------------	--------------------------	------------------------	---------------------------------	---------------------------

40-VCP-20010

480V ES

PLC OIT

HOA HS E-STOP

HS 20010-1 HS 20010-2

FOP

40-LCS-20004

ES 120V AIT 20004 TURB

AE 20004

FI 2001A

SALT LAKE CITY DEPARTMENT OF PUBLIC UTILITIES
CITY CREEK TREATMENT PLANT UPGRADES
BRIC PACKAGE
TREATMENT - SEDIMENTATION BASIN 2A

DESIGNED BY: BOTANI
DRAWN BY: ALAPIERE
CHECKED BY: ALPAGENDARM
APPROVED BY: BOTANI
DATE: JUNE 2024
EWO NO: 512260079
ACCOUNT NO: 512260079

SCALE: _____

VERIFY SCALE
BAR IS ONE INCH ON ORIGINAL DRAWING

REVISIONS

NO.	DATE	DESCRIPTION
0	06/14/24	ISSUED FOR GUARANTEE MAXIMUM PRICE (GMP)
1	06/27/24	REVISED FOR GUARANTEE MAXIMUM PRICE (GMP)

SALT LAKE CITY

90% GMP

DRAWING NO.
35-PI-13

Brown and Caldwell

C:\Users\alapiere\AppData\Local\Autodesk\AutoCAD Plant_3D\CollaborationCache\153020-SUCDPL_City_Creek_WTP-V2021\PID_DWG\35-PI-14.dwg Jun 21, 2024 -- 2:37pm

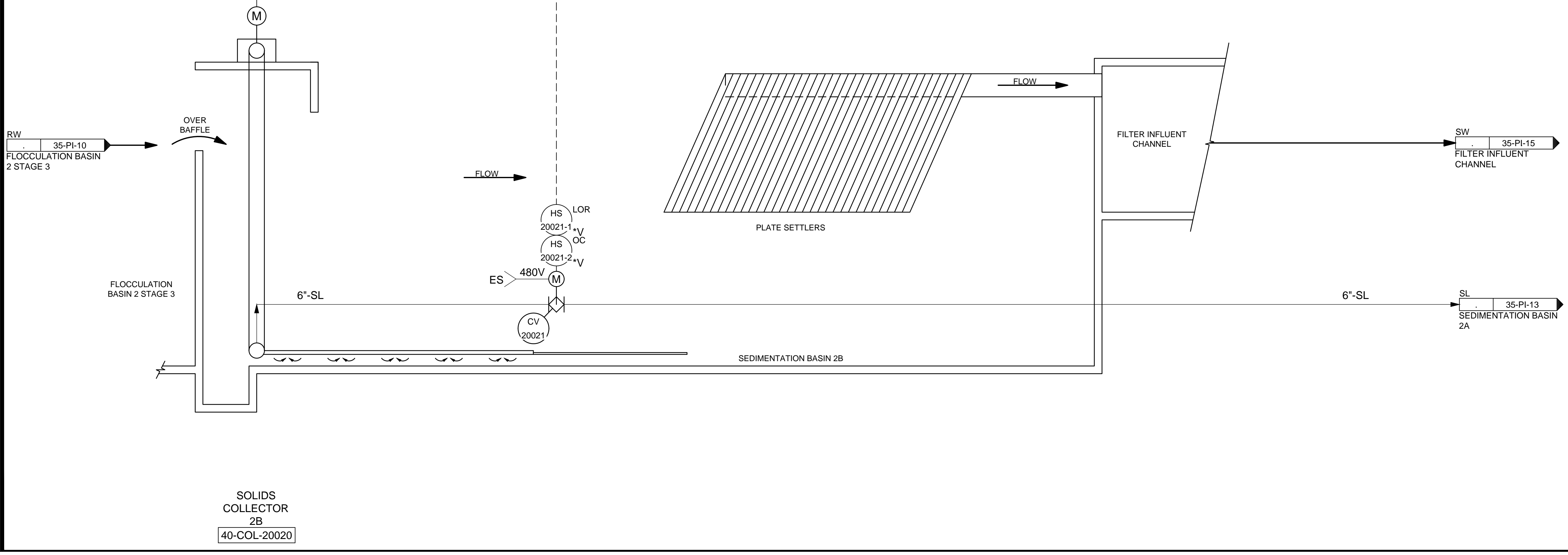
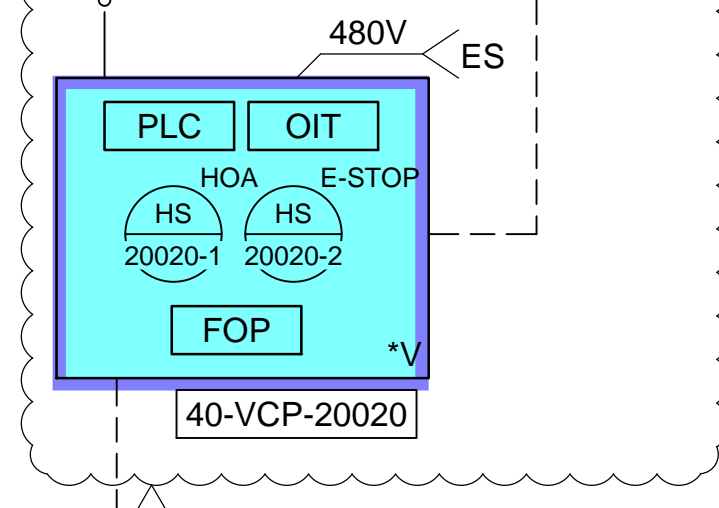
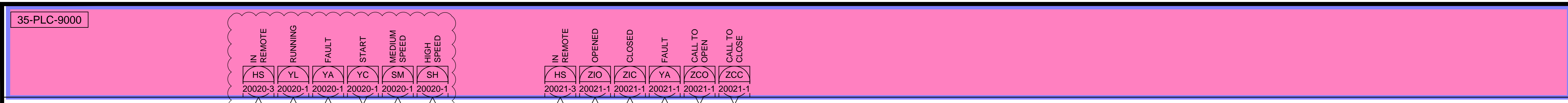

DESIGNED BY: BOTANI
 DRAWN BY: ALAPIERE
 CHECKED BY: ALPAGENDARM
 APPROVED BY: BOTANI
 DATE: JUNE 2024
 EMO NO: ---
 ACCOUNT NO: 512260079

SCALE: _____

VERIFY SCALE
 BAR IS ONE INCH ON ORIGINAL DRAWING

NO.	DATE	REVISIONS	MADE BY	AUTH BY
0	06/14/24	ISSUED FOR GUARANTEE MAXIMUM PRICE (GMP)	BO	BO
1	06/27/24	REVISED FOR GUARANTEE MAXIMUM PRICE (GMP)	BO	BO

SALT LAKE CITY DEPARTMENT OF PUBLIC UTILITIES
 CITY CREEK TREATMENT PLANT UPGRADES
 BRIC PACKAGE
**TREATMENT - SEDIMENTATION
 BASIN 2B**

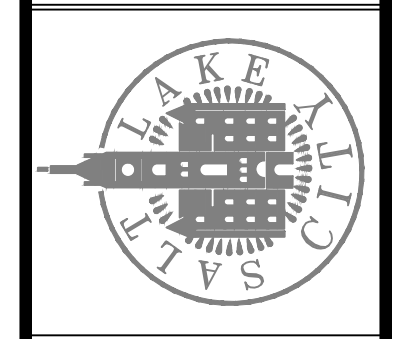

90% GMP

Brown and Caldwell

DRAWING NO.
35-PI-14

35-PI-9000

LEVEL
LI
00016-1

C:\Users\lapierre\AppData\Local\Autodesk\AutoCAD Plant_3D\CollaborationCache\153020-SLICD\PUL_City_Creek_WTP-V2021\PID_DWG\35-PI-15.dwg Jun 12, 2024 -- 4:45pm

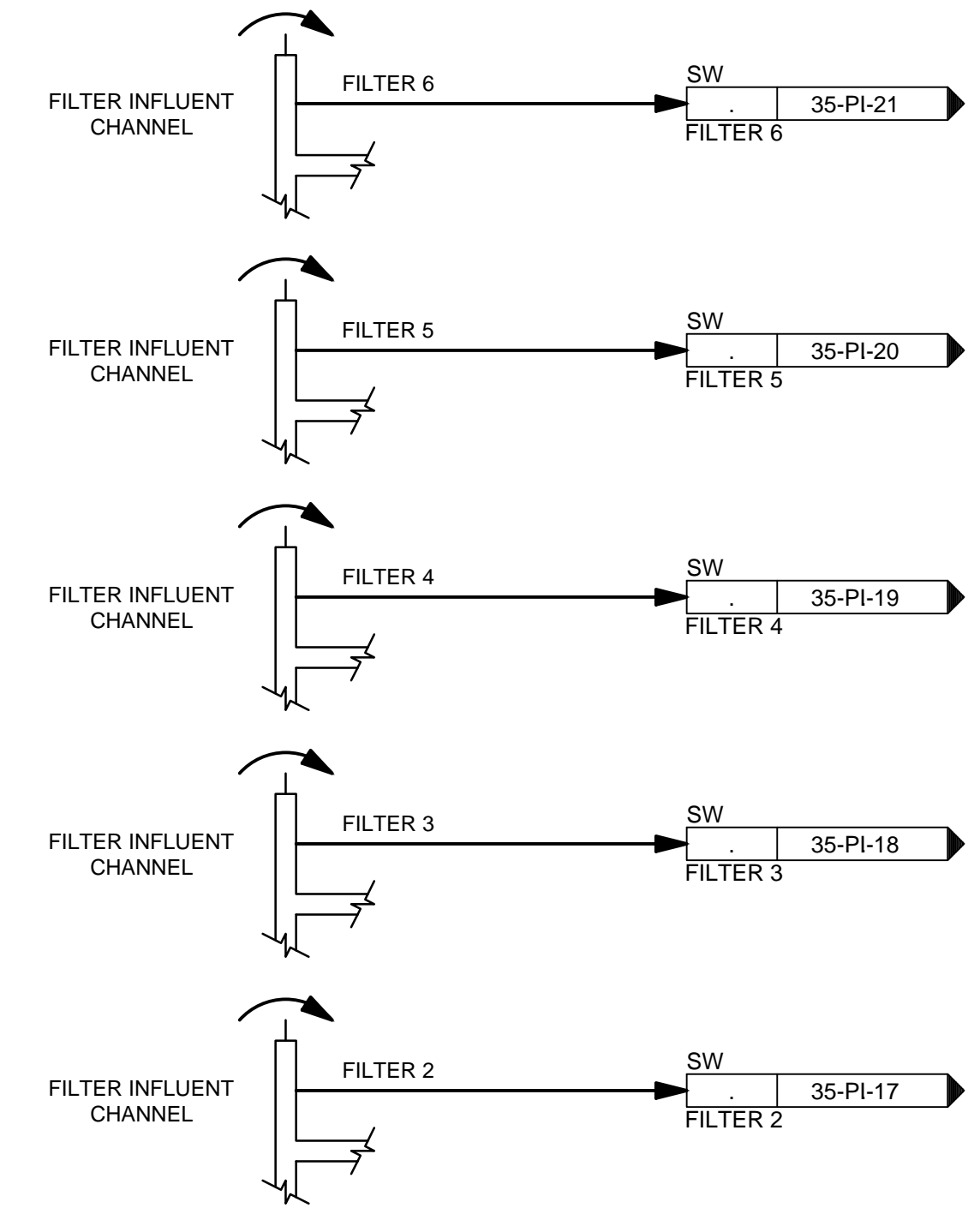
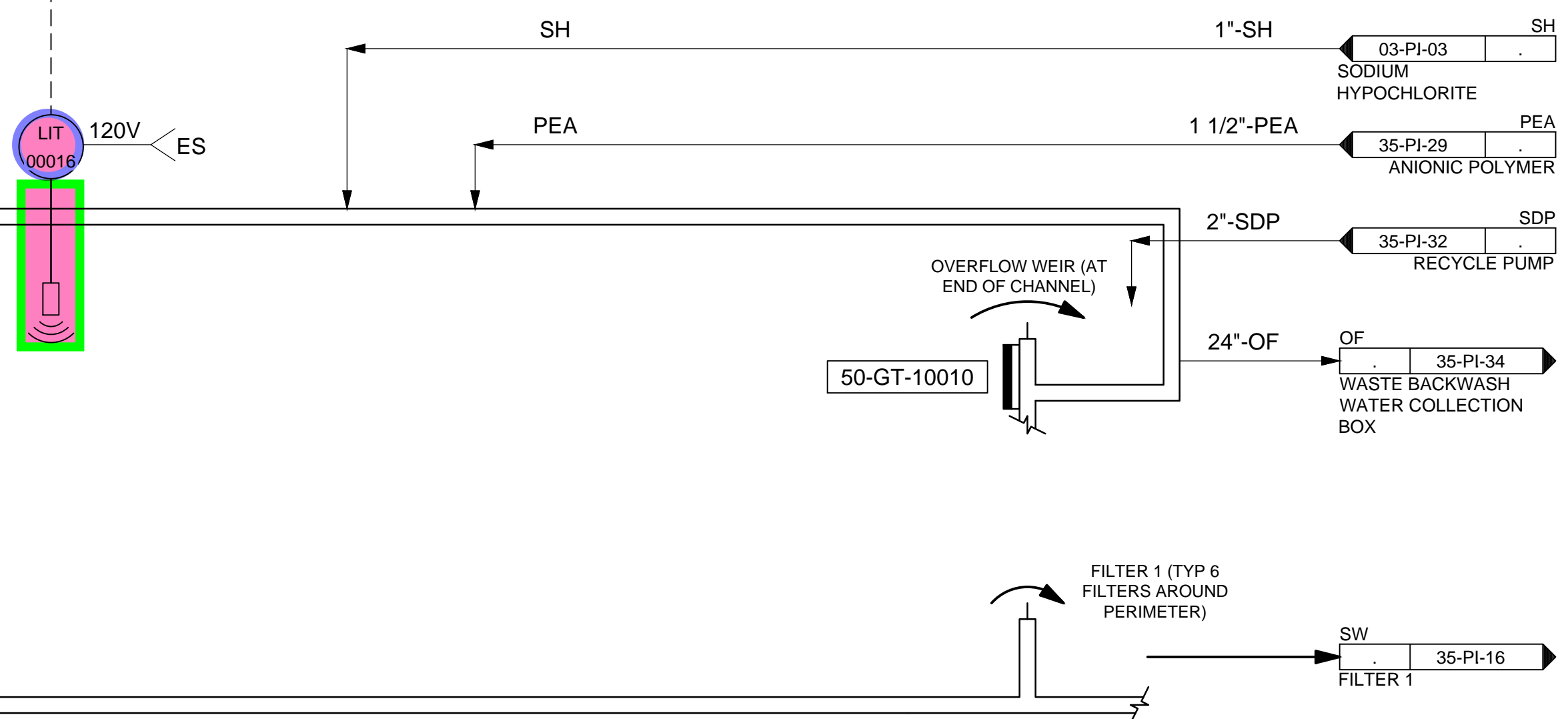
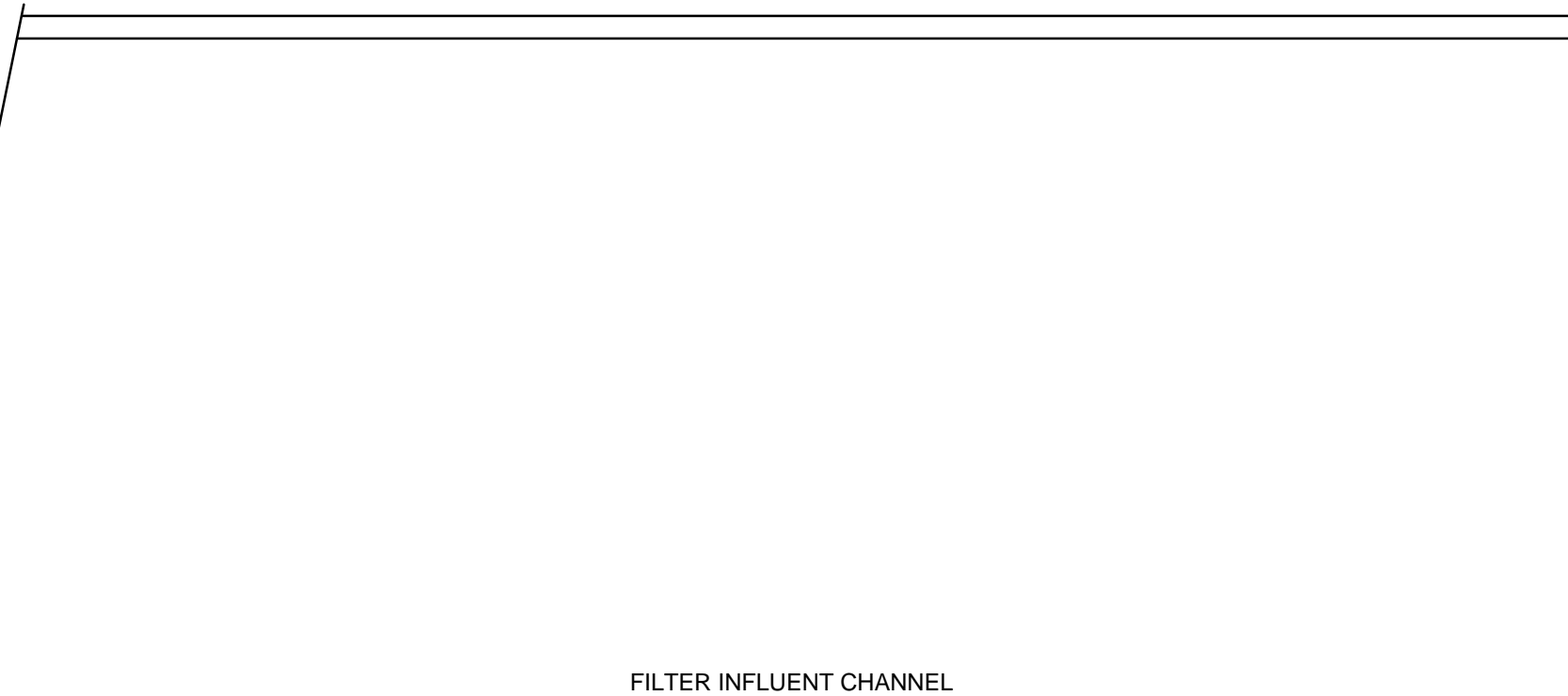
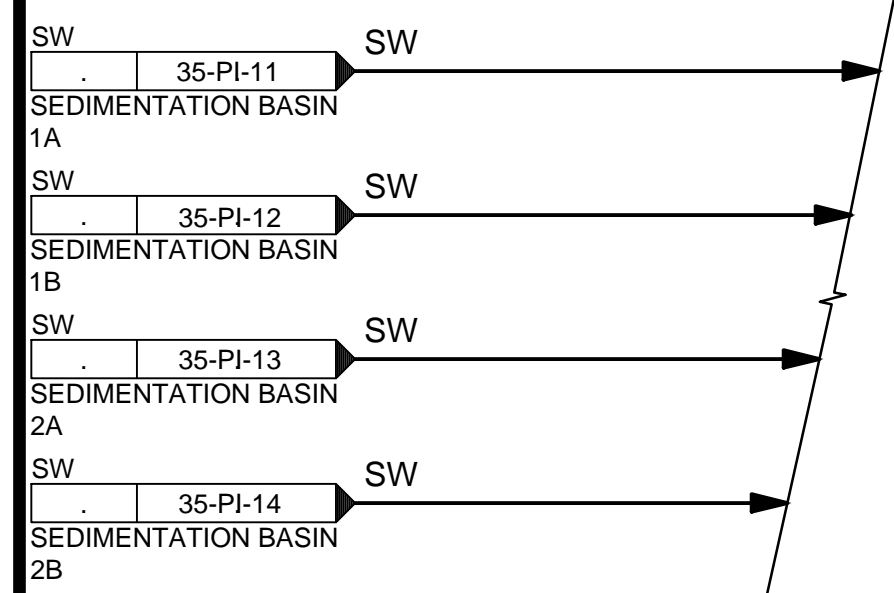

DESIGNED BY: B. OTANI
DRAWN BY: A. LAPIERRE
CHECKED BY: M. PAGEZDARM
APPROVED BY: B. OTANI
DATE: JUNE 2024
EWO NO: 512260079
ACCOUNT NO: 512260079

SCALE: _____

VERIFY SCALE
BAR IS ONE INCH ON ORIGINAL DRAWING

NO.	DATE	REVISIONS
0	06/14/24	ISSUED FOR GUARANTEE MAXIMUM PRICE (GMP)

SALT LAKE CITY DEPARTMENT OF PUBLIC UTILITIES
CITY CREEK TREATMENT PLANT UPGRADES
BRIC PACKAGE
TREATMENT - FILTER INLET CHANNEL

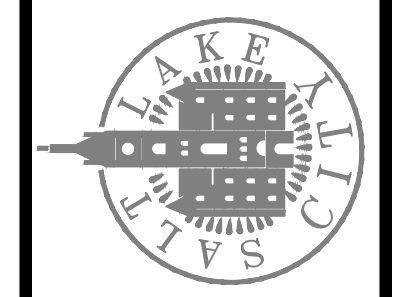

90% GMP

DRAWING NO.
35-PI-15

Brown and Caldwell

C:\Users\alapiere\AppData\Local\Autodesk\AutoCAD Plant_3D\CollaborationCache\153020-SLICDPL_City_Creek_WTP-V2021\PID_DWG\35-PI-16.dwg Jun 12, 2024 -- 4:46pm

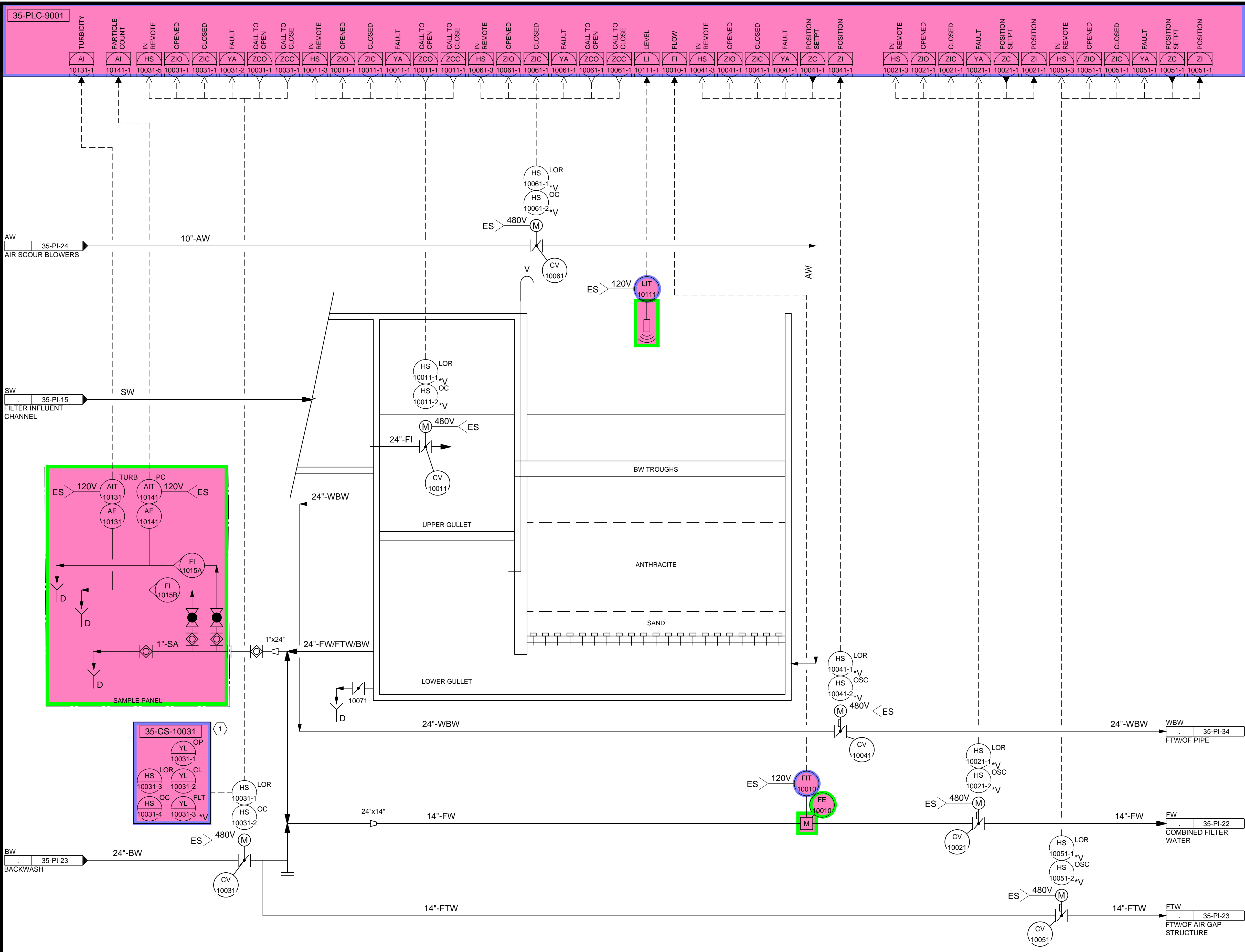

KEYNOTES:

- 1 PROVIDE A REMOTE CONTROL STATION FOR THE ACTUATOR TO BE MOUNTED 48" ABOVE THE FLOOR ELEVATION. REMOTE CONTROL STATION SHALL BE RATED FOR NEMA 4X AND HAVE THE SAME FUNCTIONALITY AS THE ACTUATOR FACEPLATE.

Brown and Caldwell

DESIGNED BY: BOTANI		SCALE:	
DRAWN BY: ALAPIERE		REVISIONS	
CHECKED BY: J.PAGENDARM		NO.	DATE
APPROVED BY: BOTANI		0	06/14/24
DATE: JUNE 2024		ISSUED FOR GUARANTEE MAXIMUM PRICE (GMP)	
EWO NO: ---		TREATMENT - FILTER 1	
ACCOUNT NO: 512260079		SALT LAKE CITY DEPARTMENT OF PUBLIC UTILITIES	
VERIFY SCALE		CITY CREEK TREATMENT PLANT UPGRADES	
BAR IS ONE INCH ON ORIGINAL DRAWING		BRIC PACKAGE	
		90% GMP	
		DRAWING NO.	
		35-PI-16	

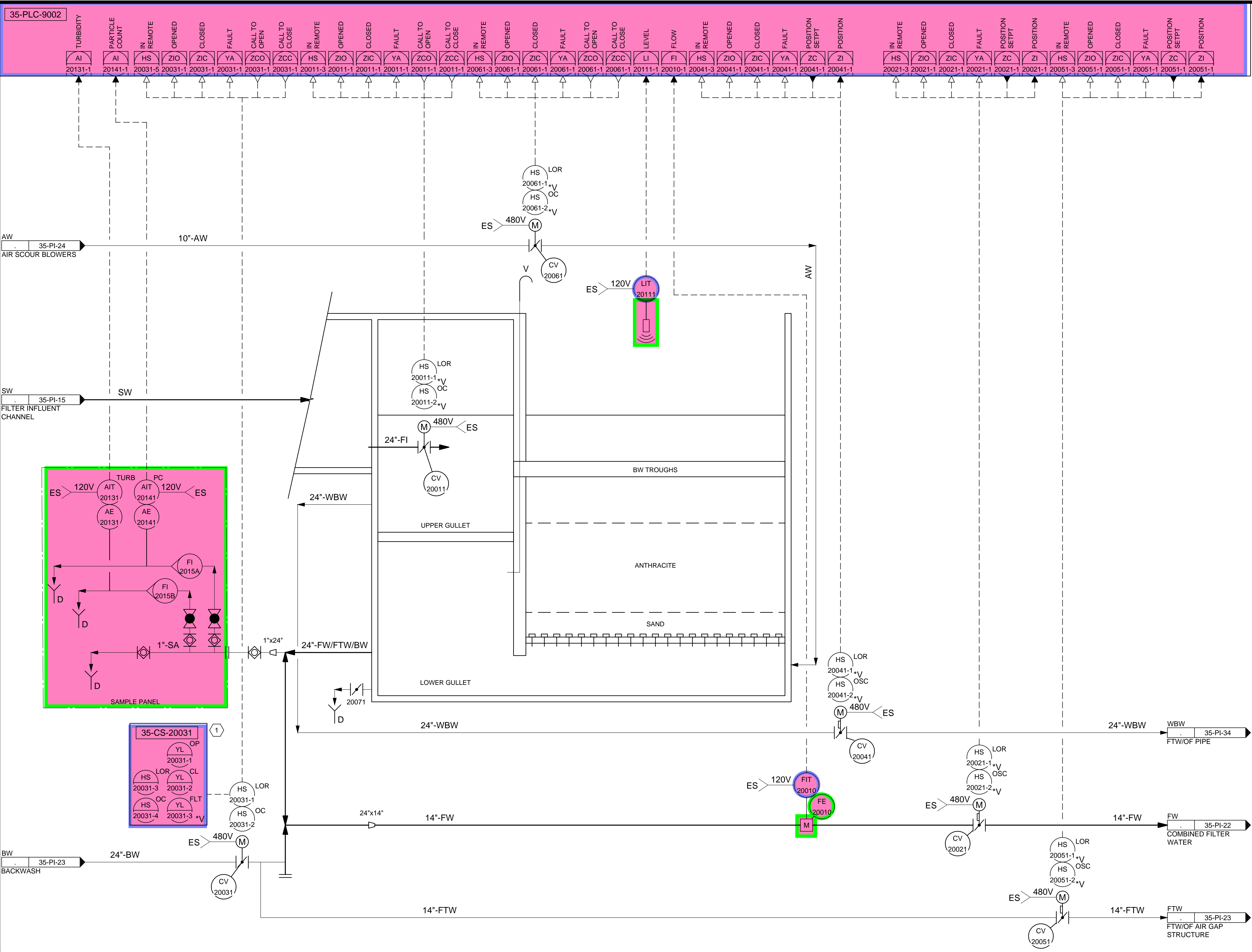

KEYNOTES:

1 PROVIDE A REMOTE CONTROL STATION FOR THE ACTUATOR TO BE MOUNTED 48" ABOVE THE FLOOR ELEVATION. REMOTE CONTROL STATION SHALL BE RATED FOR NEMA 4X AND HAVE THE SAME FUNCTIONALITY AS THE ACTUATOR FACEPLATE.

DESIGNED BY: BOTANI
 DRAWN BY: ALAPIERRE
 CHECKED BY: J. PAGENDARM
 APPROVED BY: BOTANI
 DATE: JUNE 2024
 EMO NO.:
 ACCOUNT NO.: 512260079

SCALE:
 VERIFY SCALE
 BAR IS ONE INCH ON ORIGINAL DRAWING

REVISIONS

NO.	DATE	ISSUED FOR	GUARANTEE MAXIMUM PRICE (GMP)
0	06/14/24		

DESIGNED BY: BOTANI
 AUTH. BY: BO
 MADE BY: BO
 DATE:

SALT LAKE CITY DEPARTMENT OF PUBLIC UTILITIES
 CITY CREEK TREATMENT PLANT UPGRADES
 BRIC PACKAGE
TREATMENT - FILTER 2

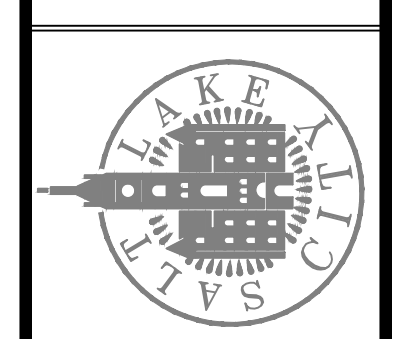

90% GMP

DRAWING NO.
35-PI-17

Brown and Caldwell

C:\Users\alapierre\AppData\Local\Autodesk\AutoCAD Plant_3D\CollaborationCache\153020-SLICDPL_City_Creek_WTP-V2021\PID_DWG\35-PI-17.dwg Jun 12, 2024 - 4:47pm

C:\Users\alapiere\AppData\Local\Autodesk\AutoCAD Plant_3D\Collaboration\AutoCAD Plant_3D\Collaboration\Cached\153020-SLCPDPL_City_Creek_WTP-V2021\PID_DWG\35-PI-18.dwg Jun 12, 2024 4:46pm

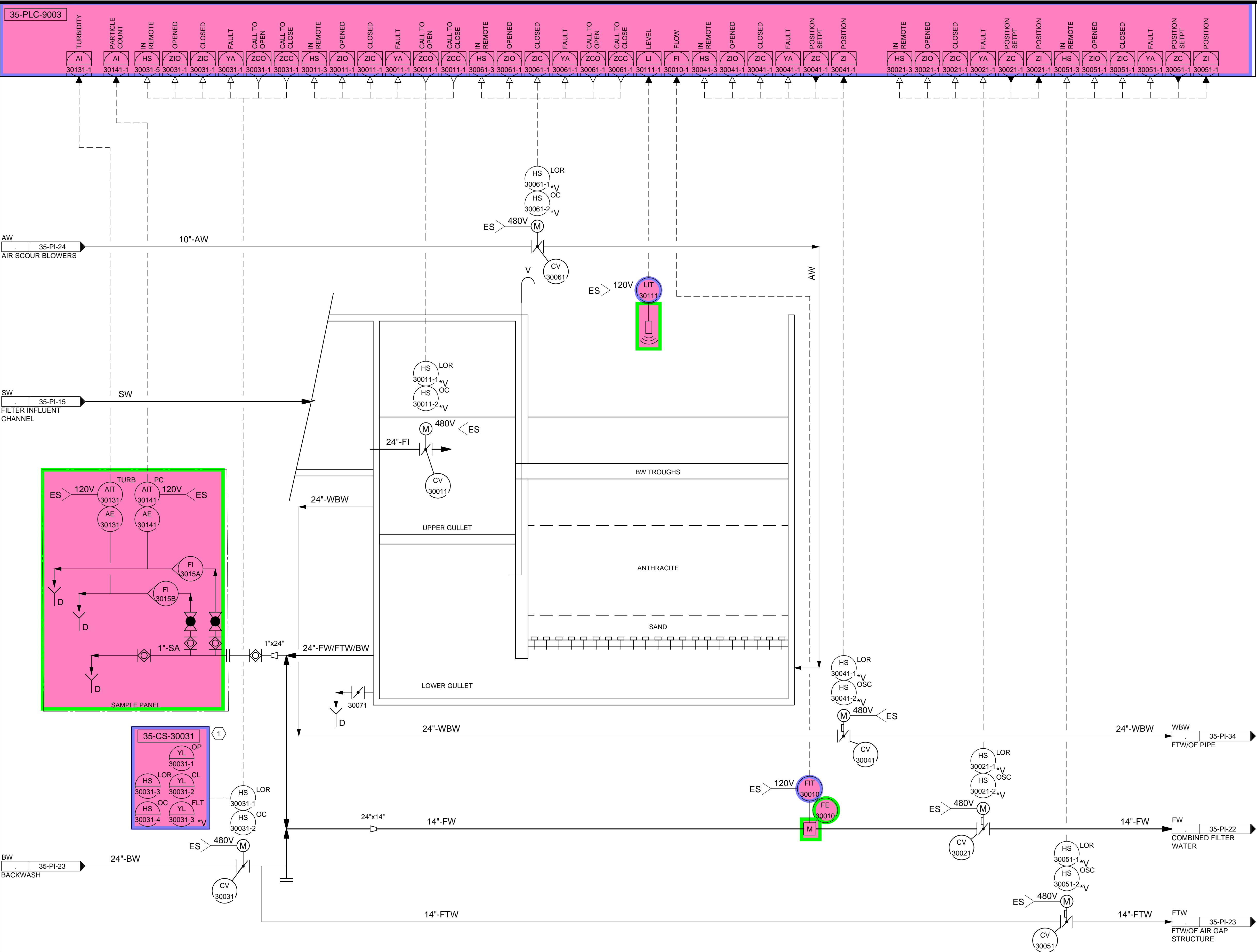

KEYNOTES:

1 PROVIDE A REMOTE CONTROL STATION FOR THE ACTUATOR TO BE MOUNTED 48" ABOVE THE FLOOR ELEVATION. REMOTE CONTROL STATION SHALL BE RATED FOR NEMA 4X AND HAVE THE SAME FUNCTIONALITY AS THE ACTUATOR FACEPLATE.

REVISIONS

NO.	DATE	BY	REVISION
0	06/14/24	J.PAGENDARM	ISSUED FOR GUARANTEE MAXIMUM PRICE (GMP)

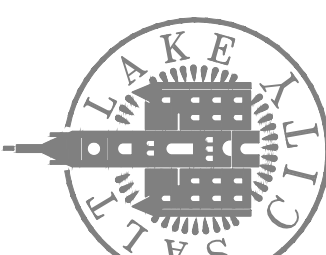
DESIGNED BY: BOTANI		DRAWN BY: ALAPIERE		CHECKED BY: J.PAGENDARM		APPROVED BY: BOTANI		DATE: JUNE 2024		EWO NO: 51226079	
SCALE:											
AUTH: BY BO		MADE BY BO		REVISED BY BO							
SALT LAKE CITY DEPARTMENT OF PUBLIC UTILITIES											
CITY CREEK TREATMENT PLANT UPGRADES											
BRIC PACKAGE											
TREATMENT - FILTER 3											
											
90% GMP											
DRAWING NO. 35-PI-18											

Brown and Caldwell

C:\Users\alapiere\AppData\Local\Autodesk\AutoCAD Plant 3D\CollaborationCache\153020-SLICDPL_City_Creek_WTP-V2021\PID_DWG\35-PI-19.dwg Jun 12, 2024 -- 4:46pm

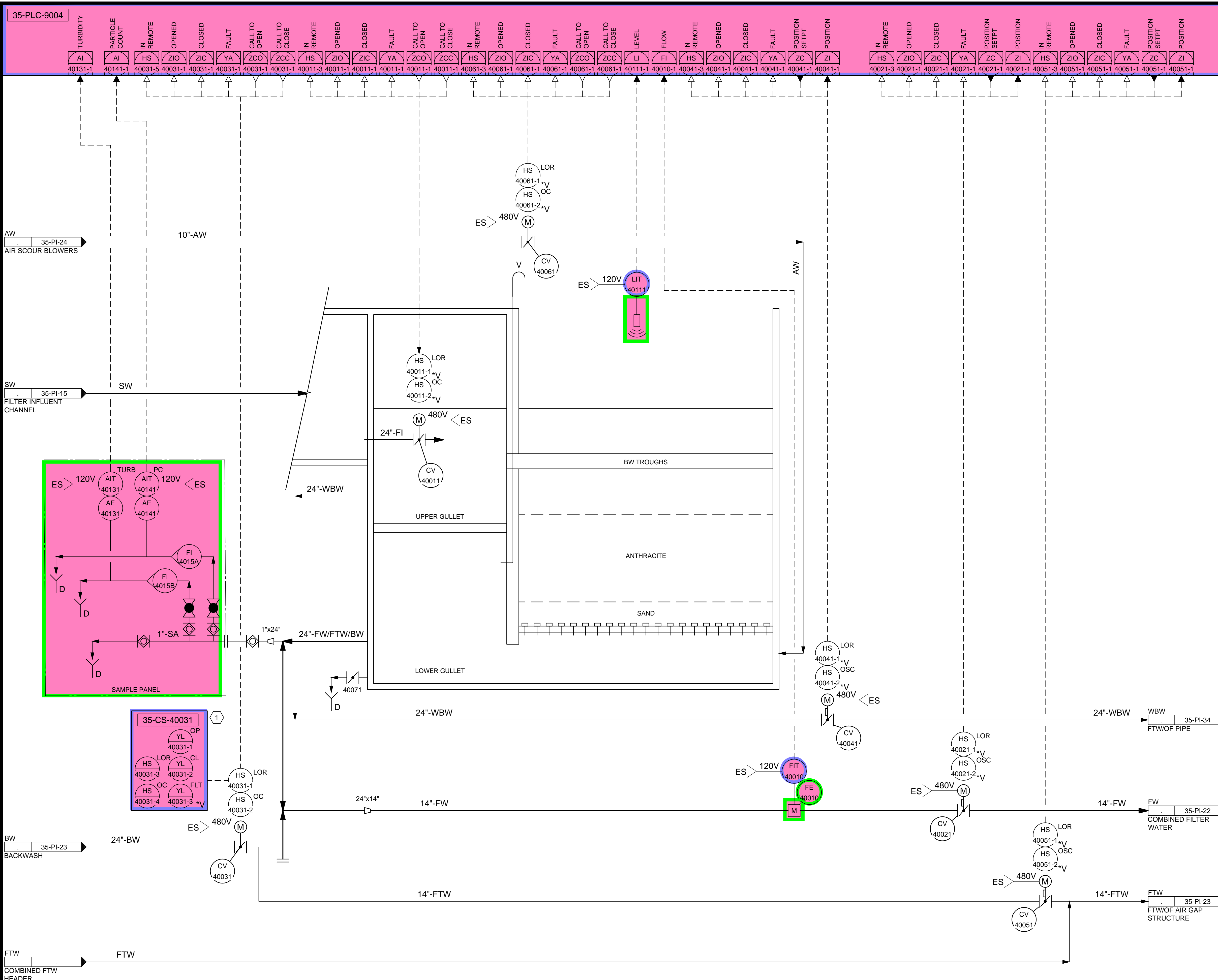

KEYNOTES:

- 1 PROVIDE A REMOTE CONTROL STATION FOR THE ACTUATOR TO BE MOUNTED 48" ABOVE THE FLOOR ELEVATION. REMOTE CONTROL STATION SHALL BE RATED FOR NEMA 4X AND HAVE THE SAME FUNCTIONALITY AS THE ACTUATOR FACEPLATE.

DESIGNED BY: BOTANI
 DRAWN BY: ALAPIERE
 CHECKED BY: J.PAGENDARM
 APPROVED BY: BOTANI
 DATE: JUNE 2024
 EMO NO: --
 ACCOUNT NO: 512260079

SCALE: _____

VERIFY SCALE
 BAR IS ONE INCH ON ORIGINAL DRAWING

REVISIONS

NO.	DATE	BY	REASON
0	06/14/24	ISSUED FOR GUARANTEE MAXIMUM PRICE (GMP)	

SALT LAKE CITY DEPARTMENT OF PUBLIC UTILITIES
 CITY CREEK TREATMENT PLANT UPGRADES
 BRIC PACKAGE
TREATMENT - FILTER 4

90% GMP

DRAWING NO.
35-PI-19

Brown and Caldwell

C:\Users\alapiere\AppData\Local\Autodesk\AutoCAD Plant 3D\Collaboration\Autocad\153020-SLICD\PL City_Creek_WTP-V2021\PID_DWG\35-PI-20.dwg Jun 12, 2024 -- 4:50pm

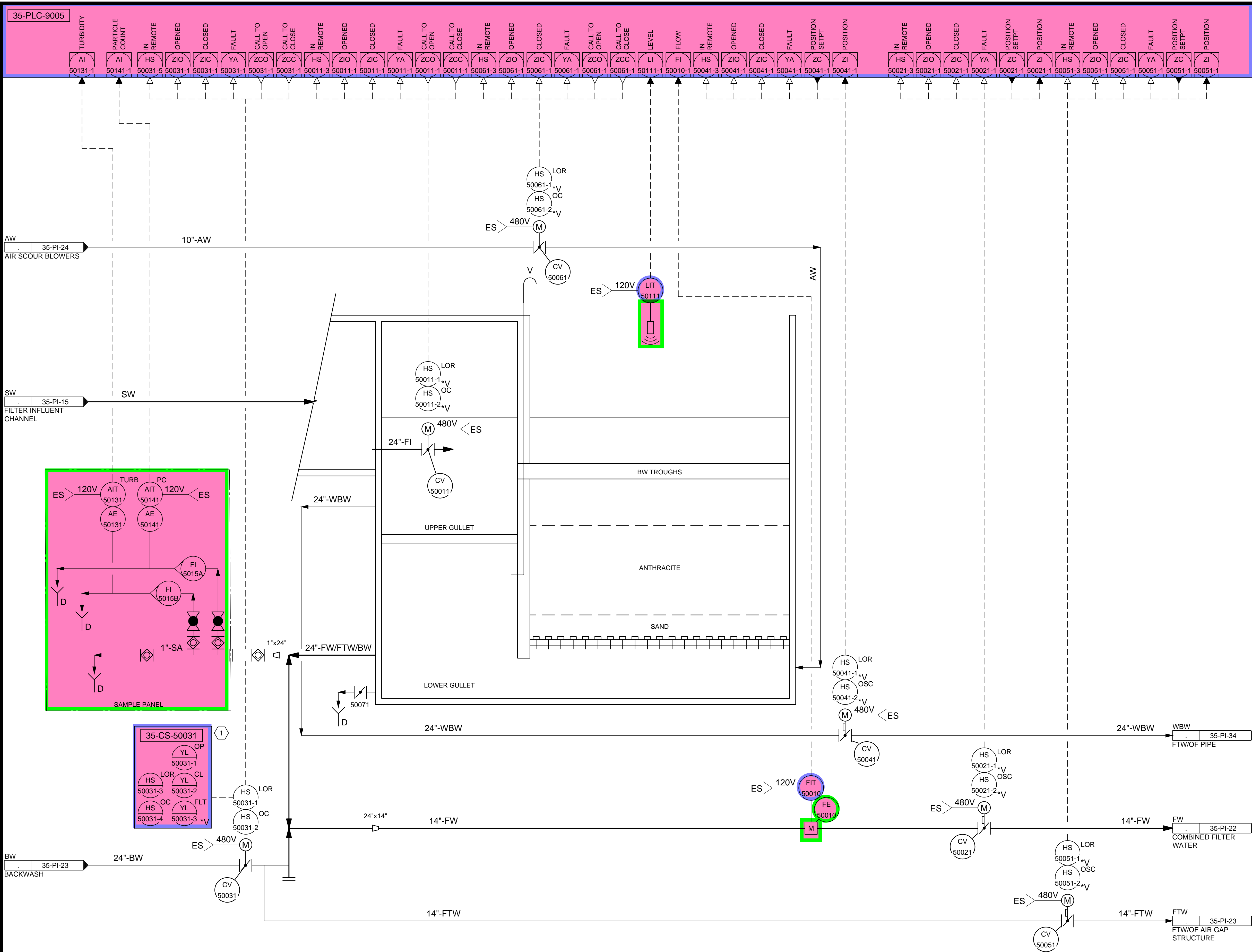

KEYNOTES:

- 1 PROVIDE A REMOTE CONTROL STATION FOR THE ACTUATOR TO BE MOUNTED 48" ABOVE THE FLOOR ELEVATION. REMOTE CONTROL STATION SHALL BE RATED FOR NEMA 4X AND HAVE THE SAME FUNCTIONALITY AS THE ACTUATOR FACEPLATE.

DESIGNED BY: BOTANI		AUTH: BY	
DRAWN BY: ALAPIERE		BO	
CHECKED BY: J.PAGENDARM		BO	
APPROVED BY: BOTANI		BO	
DATE: JUNE 2024		BO	
EWO NO: ---		BO	
ACCOUNT NO: 512260079		BO	

SCALE: ---

REVISIONS

NO.	DATE	ISSUED FOR	GUARANTEE	MAXIMUM PRICE (GMP)
0	06/14/24			

SALT LAKE CITY DEPARTMENT OF PUBLIC UTILITIES
CITY CREEK TREATMENT PLANT UPGRADES
BRIC PACKAGE
TREATMENT - FILTER 5

90% GMP

DRAWING NO.
35-PI-20

Brown and Caldwell

VERIFY SCALE
BAR IS ONE INCH ON ORIGINAL DRAWING

C:\Users\alapiere\AppData\Local\Autodesk\AutoCAD Plant_3D\CollaborationCache\153020-SICD\PL_City_Creek_WTP-V2021\PID_DWG\35-PI-21.dwg Jun 12, 2024 - 4:24pm

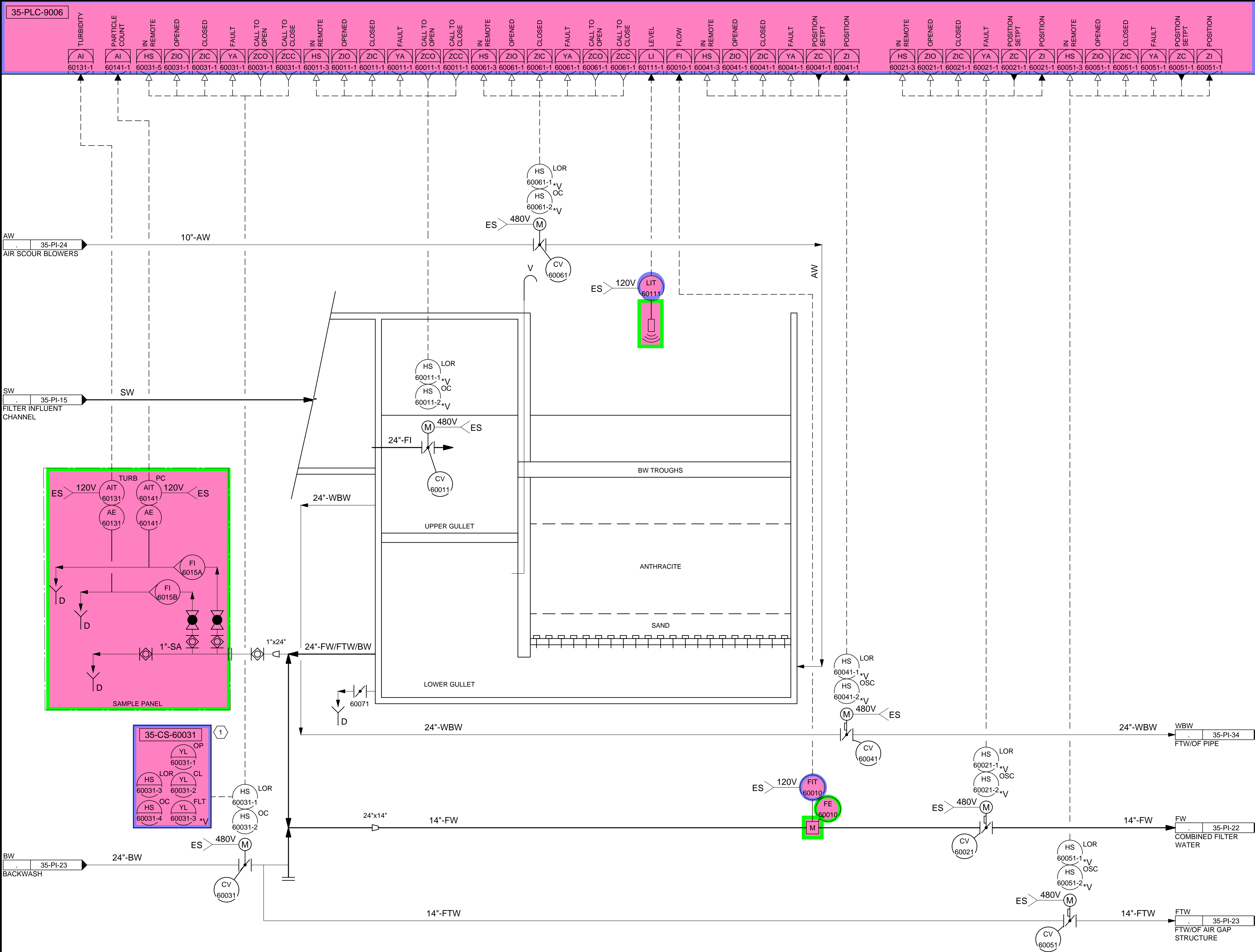

KEYNOTES:

1 PROVIDE A REMOTE CONTROL STATION FOR THE ACTUATOR TO BE MOUNTED 48" ABOVE THE FLOOR ELEVATION. REMOTE CONTROL STATION SHALL BE RATED FOR NEMA 4X AND HAVE THE SAME FUNCTIONALITY AS THE ACTUATOR FACEPLATE.

35-PLC-9006	
TURBIDITY	Ai 60131-1
PARTICLE COUNT	Ai 60141-1
IN REMOTE	HS 60031-5
OPENED	ZIO 60031-1
CLOSED	ZIC 60031-1
FAULT	YA 60031-1
CALL TO OPEN	ZCO 60031-1
CALL TO CLOSE	ZCC 60031-1
IN REMOTE	HS 60011-3
OPENED	ZIO 60011-1
CLOSED	ZIC 60011-1
FAULT	YA 60011-1
CALL TO OPEN	ZCO 60011-1
CALL TO CLOSE	ZCC 60011-1
IN REMOTE	HS 60061-3
OPENED	ZIO 60061-1
CLOSED	ZIC 60061-1
FAULT	YA 60061-1
CALL TO OPEN	ZCO 60061-1
CALL TO CLOSE	ZCC 60061-1
LEVEL	LI 60111-1
FLOW	FI 60010-1
IN REMOTE	HS 60041-3
OPENED	ZIO 60041-1
CLOSED	ZIC 60041-1
FAULT	YA 60041-1
POSITION SETPT	ZC 60041-1
POSITION	ZI 60041-1
IN REMOTE	HS 60021-3
OPENED	ZIO 60021-1
CLOSED	ZIC 60021-1
FAULT	YA 60021-1
POSITION SETPT	ZC 60021-1
POSITION	ZI 60021-1
IN REMOTE	HS 60051-3
OPENED	ZIO 60051-1
CLOSED	ZIC 60051-1
FAULT	YA 60051-1
POSITION SETPT	ZC 60051-1
POSITION	ZI 60051-1

DESIGNED BY: BOTANI
 DRAWN BY: ALAPIERE
 CHECKED BY: J.PAGENDARM
 APPROVED BY: BOTANI
 DATE: JUNE 2024
 EMO NO.:
 ACCOUNT NO.: 512260079

SCALE:

REVISIONS

NO.	DATE	BY	DESCRIPTION
0	06/14/24	ISSUED FOR GUARANTEE MAXIMUM PRICE (GMP)	

SALT LAKE CITY DEPARTMENT OF PUBLIC UTILITIES
 CITY CREEK TREATMENT PLANT UPGRADES
 BRIC PACKAGE
TREATMENT - FILTER 6

90% GMP

DRAWING NO.
35-PI-21

Brown and Caldwell

VERIFY SCALE
 BAR IS ONE INCH ON ORIGINAL DRAWING

C:\Users\Valpierre\AppData\Local\Autodesk\AutoCAD Plant 3D\Collaboration\Coche\153020-SLCDPU_City_Creek_WTP-V2021\PID_DWG\35-PI-22.dwg Jun 12, 2024 - 7:44pm

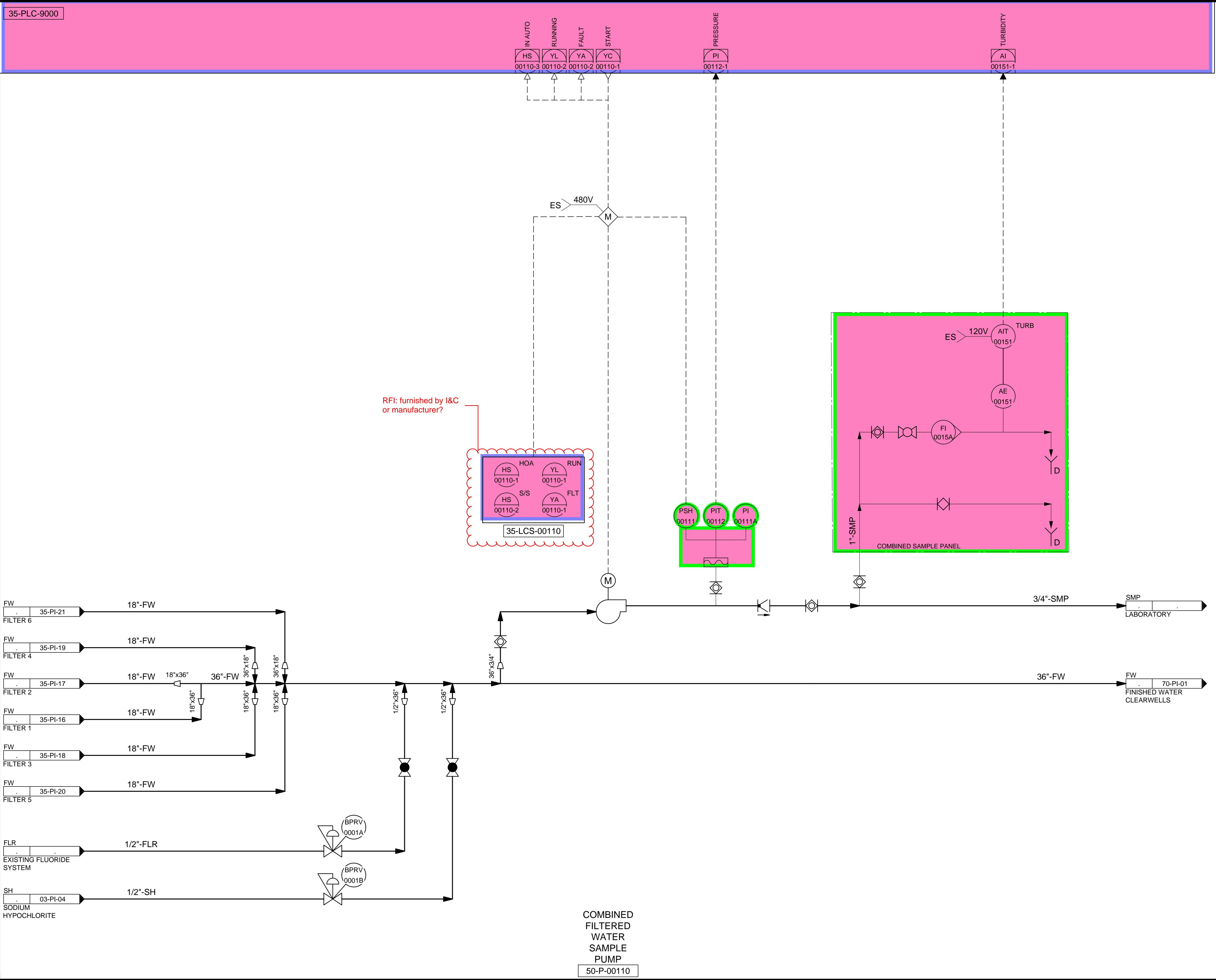

35-PLC-9000

IN AUTO (HS 00110-3)
 RUNNING (YL 00110-2)
 FAULT (YA 00110-2)
 START (YC 00110-1)

PRESSURE (PI 00112-1)

TURBIDITY (AI 00151-1)

RFI: furnished by I&C or manufacturer?

35-LCS-00110

HOA (HS 00110-1)
 RUN (YL 00110-1)
 S/S (HS 00110-2)
 FLT (YA 00110-1)

PSH 00111
 PIT 00112
 PI 00114

120V
 ES
 AIT 00151
 TURB
 AE 00151
 FI 0015A
 1" SMP
 3/4" SMP
 36" FW
 70-PI-01
 FINISHED WATER CLEARWELLS

COMBINED SAMPLE PANEL

COMBINED FILTERED WATER SAMPLE PUMP
 50-P-00110

DESIGNED BY: B.OTANI
 DRAWN BY: A.LAPIERRE
 CHECKED BY: M.PAGENDARM
 APPROVED BY: B.OTANI
 DATE: JUNE 2024
 EWO NO: --
 ACCOUNT NO: 512260079

SCALE: _____

VERIFY SCALE
 BAR IS ONE INCH ON ORIGINAL DRAWING

REVISIONS

NO.	DATE	BY	DESCRIPTION
0	06/14/24	ISSUED FOR GUARANTEE MAXIMUM PRICE (GMP)	

SALT LAKE CITY DEPARTMENT OF PUBLIC UTILITIES
 CITY CREEK TREATMENT PLANT UPGRADES
 BRIC PACKAGE
TREATMENT - COMBINED FILTERED WATER

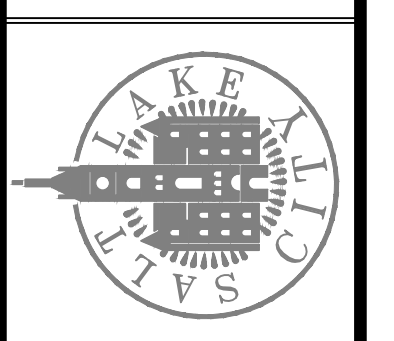

90% GMP

DRAWING NO.
35-PI-22

Brown and Caldwell

C:\Users\alapiere\AppData\Local\Autodesk\AutoCAD Plant_3D\CollaborationCache\153020-SLICDPL_City_Creek_WTP-V2021\FID_DWG\35-PI-24.dwg Jun 24, 2024 9:43am

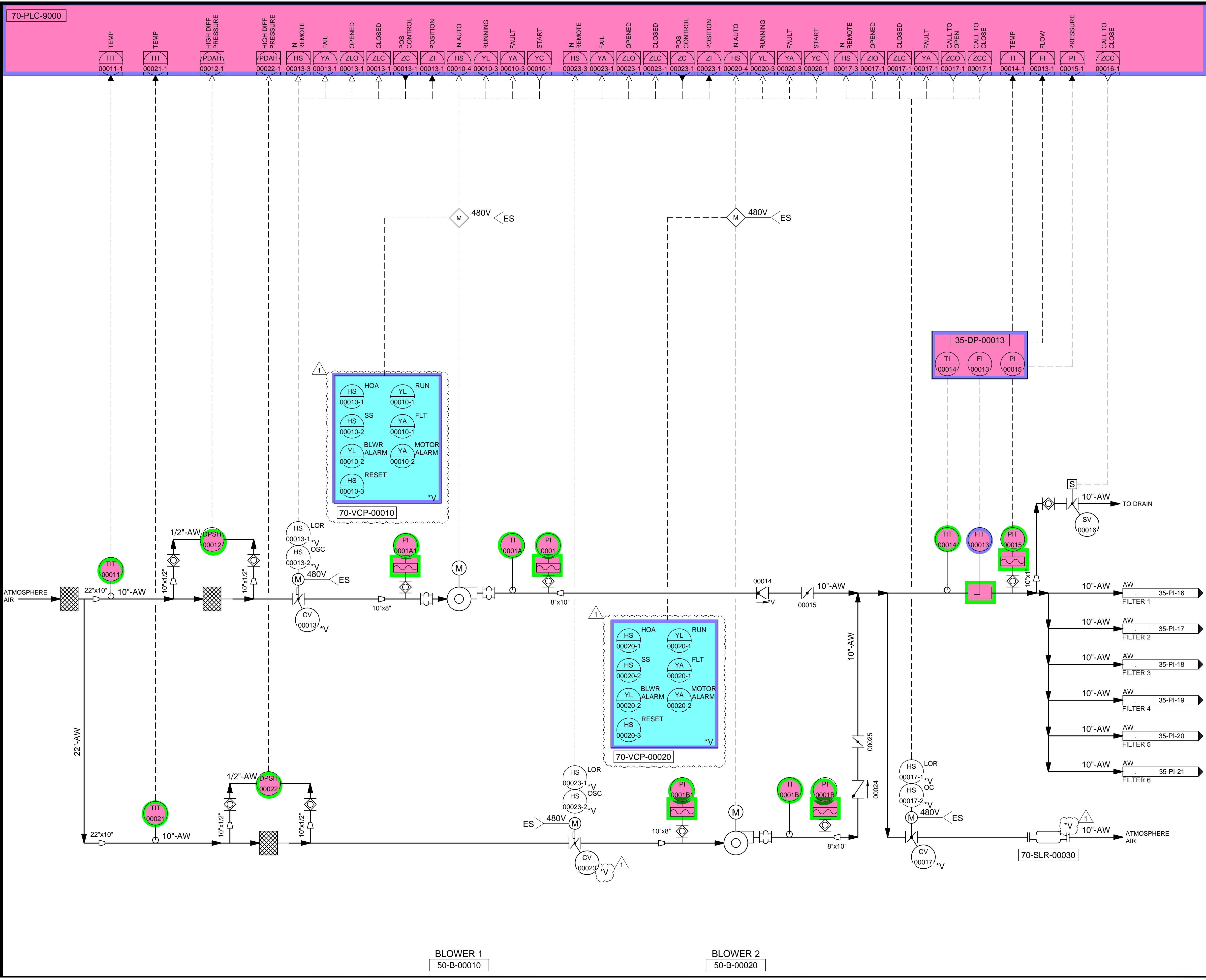

GENERAL NOTES:
 1. VMPs, CSs, AND DP ARE TO BE FIELD LOCATED.

DESIGNED BY: BOTANI		AUTH. BY:	
DRAWN BY: ALAPIERE		BO	BO
CHECKED BY: ALPAGENDARM		BO	BO
APPROVED BY: BOTANI			
DATE: JUNE 2024			
EWO NO: 512260079			
ACCOUNT NO: 512260079			

REVISIONS

NO.	DATE	ISSUED FOR	GUARANTEE	MAXIMUM PRICE (GMP)
0	06/14/24	ISSUED FOR	GUARANTEE	MAXIMUM PRICE (GMP)
1	06/27/24	REVISED FOR	GUARANTEE	MAXIMUM PRICE (GMP)

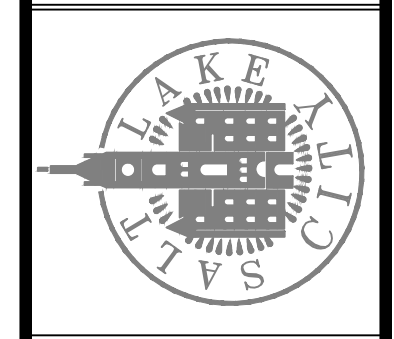

90% GMP

DRAWING NO.
35-PI-24

Brown and Caldwell

SCALE:
VERIFY SCALE
 BAR IS ONE INCH ON ORIGINAL DRAWING

BLOWER 1
50-B-00010

BLOWER 2
50-B-00020

C:\Users\alapiere\AppData\Local\Autodesk\AutoCAD Plant_3D\CollaborationCache\153020-SLICDPL_City_Creek_WTP-V2021\PID_DWG\35-PI-28.dwg Jun 12, 2024 -- 7:47pm

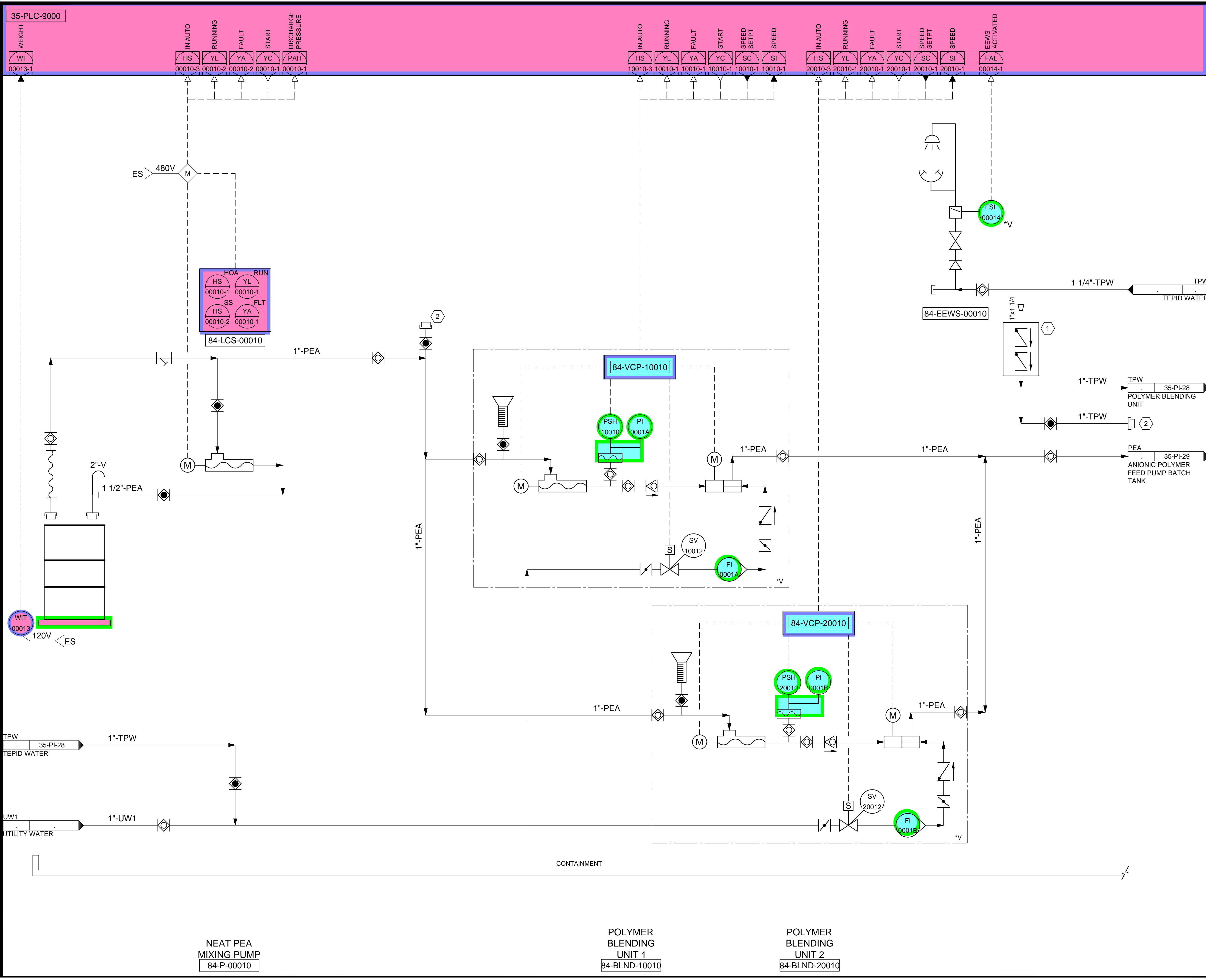

KEYNOTES:

- 1 PROVIDE BACKFLOW PREVENTER
- 2 PROVIDE HOSEBIB IN POLYMER ROOM

DESIGNED BY: BOTANI		SCALE:	
DRAWN BY: ALAPIERE			
CHECKED BY: J.PAGENDARM			
APPROVED BY: BOTANI			
DATE: JUNE 2024			
EWO NO: ---			
ACCOUNT NO: 512260079			

REVISIONS

NO.	DATE	ISSUED FOR GUARANTEE MAXIMUM PRICE (GMP)
0	06/14/24	

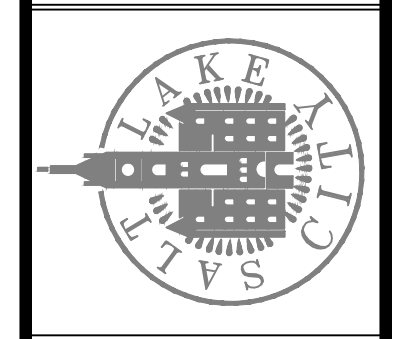

SALT LAKE CITY DEPARTMENT OF PUBLIC UTILITIES
 CITY CREEK TREATMENT PLANT UPGRADES
 BRIC PACKAGE
**TREATMENT - ANIONIC
 POLYMER STORAGE & FEED**

90% GMP

DRAWING NO.
35-PI-28

Brown and Caldwell

VERIFY SCALE
 BAR IS ONE INCH ON ORIGINAL DRAWING

C:\Users\alapiere\AppData\Local\Autodesk\AutoCAD Plant_3D\CollaborationCache\153020-S\CDP\PL City_Creek_WTP-V2021\PID_DWG\35-PI-29.dwg Jun 12, 2024 -- 7:49pm

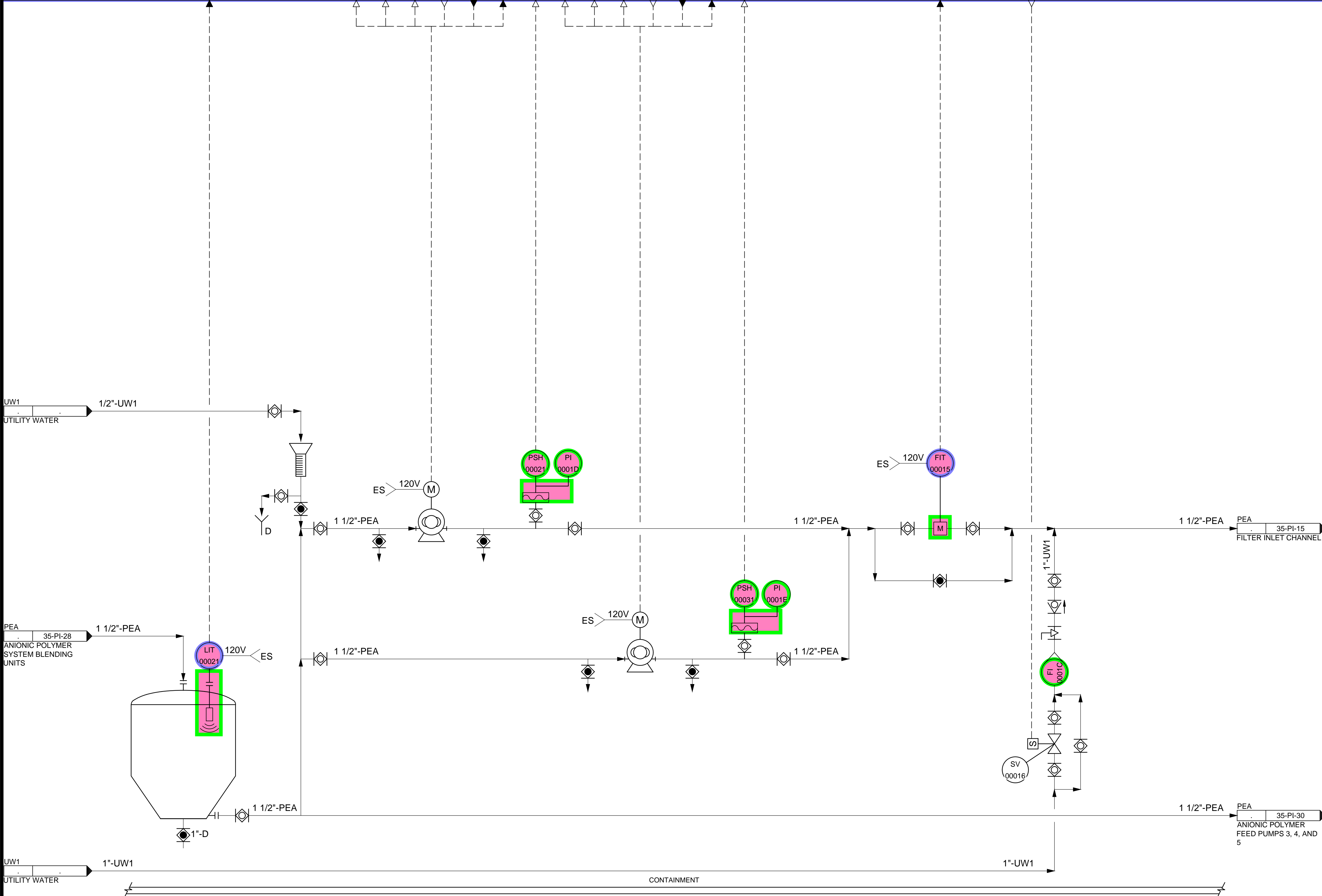
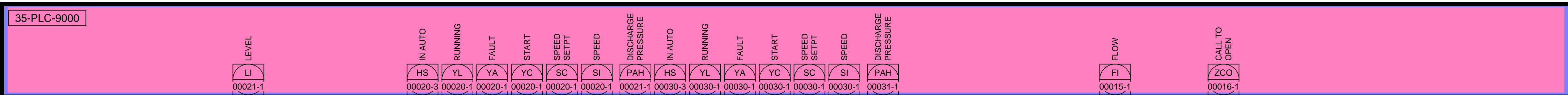

PEA BATCH TANK
84-T-00020

PEA FEED PUMP 1
84-P-00020

PEA FEED PUMP 2
84-P-00030

Brown and Caldwell

REVISIONS	
NO.	DATE
0	06/14/24

ISSUED FOR GUARANTEE MAXIMUM PRICE (GMP)

DESIGNED BY: BOTANI	AUTH. BY: BO
DRAWN BY: ALAPIERE	BY: BO
CHECKED BY: J.PAGENDARM	
APPROVED BY: BOTANI	
DATE: JUNE 2024	
EWO NO: ---	
ACCOUNT NO: 512260079	

SALT LAKE CITY DEPARTMENT OF PUBLIC UTILITIES
 CITY CREEK TREATMENT PLANT UPGRADES
 BRIC PACKAGE
**TREATMENT - ANIONIC
 POLYMER FEED PUMPS 1 & 2**

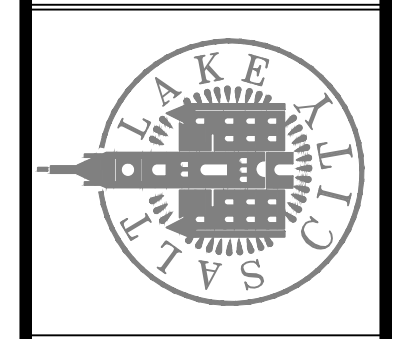

90% GMP

DRAWING NO.
35-PI-29

SCALE:
VERIFY SCALE
 BAR IS ONE INCH ON ORIGINAL DRAWING

C:\Users\alapiere\AppData\Local\Autodesk\AutoCAD Plant_3D\CollaborationCache\153020-SLICDPIP_City_Creek_WTP-V2021\PID_DWG\35-PI-30.dwg Jun 12, 2024 -- 7:50pm

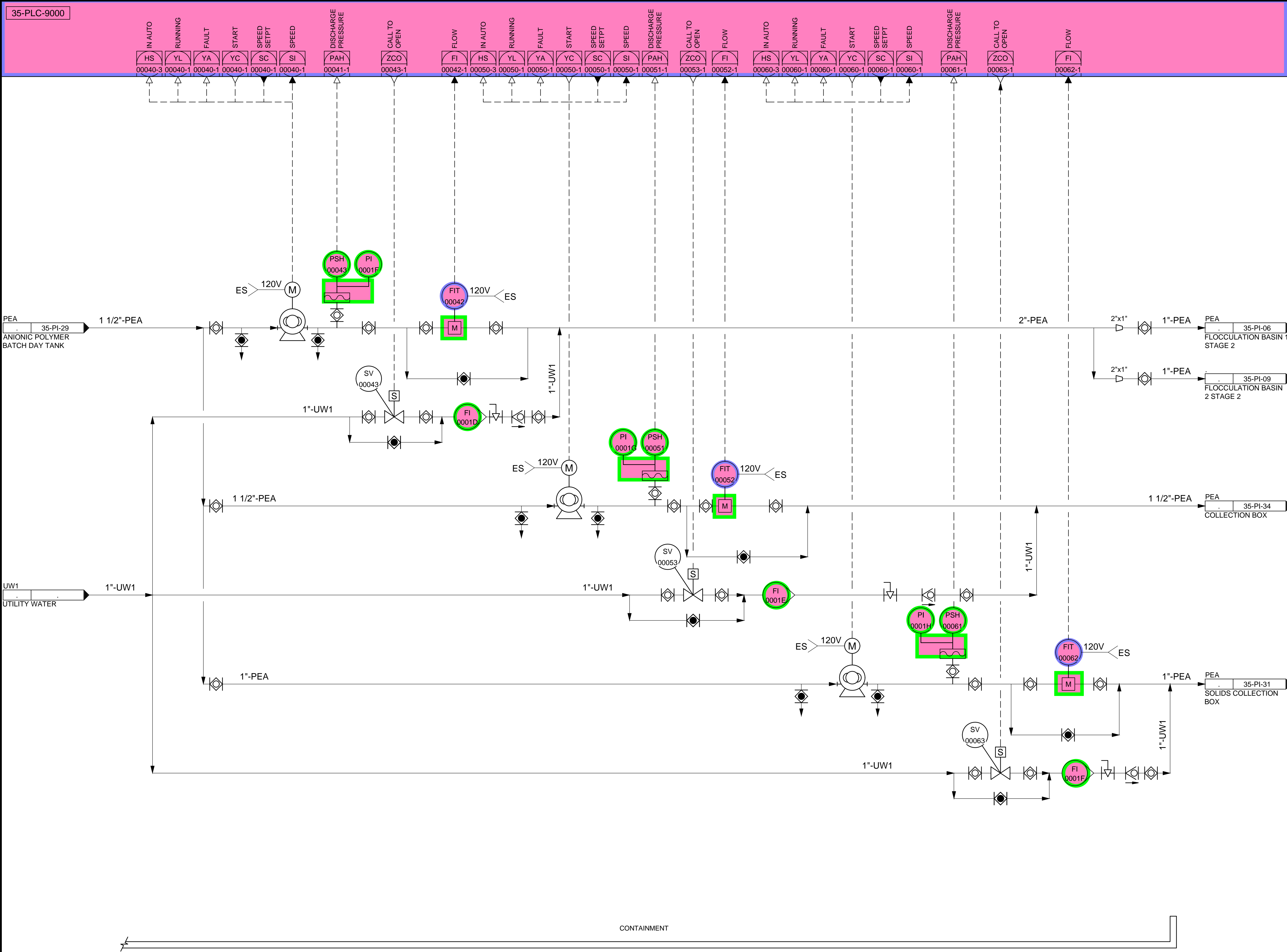

PEA FEED
PUMP 3
84-P-00040

PEA FEED
PUMP 4
84-P-00050

PEA FEED
PUMP 5
84-P-00060

CONTAINMENT

DESIGNED BY: BOTANI
DRAWN BY: ALAPIERE
CHECKED BY: ALPAGENDARM
APPROVED BY: BOTANI
DATE: JUNE 2024
EWO NO: 512260079
ACCOUNT NO: 512260079

SCALE: _____

VERIFY SCALE
BAR IS ONE INCH ON ORIGINAL DRAWING

NO.	DATE	REVISIONS
0	06/14/24	ISSUED FOR GUARANTEE MAXIMUM PRICE (GMP)

SALT LAKE CITY DEPARTMENT OF PUBLIC UTILITIES
CITY CREEK TREATMENT PLANT UPGRADES
BRIC PACKAGE

TREATMENT - ANIONIC POLYMER FEED PUMPS 3 & 4

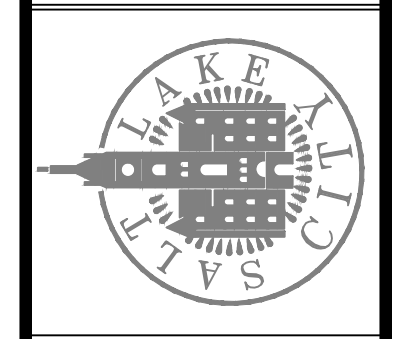

90% GMP

DRAWING NO.
35-PI-30

Brown and Caldwell

C:\Users\alapiere\AppData\Local\Autodesk\AutoCAD Plant 3D\CollaborationCache\153020-SLICDPL_City_Creek_WTP-V2021\PID_DWG\35-PI-31.dwg Jun 12, 2024 -- 7:52pm

35-PLC-9000

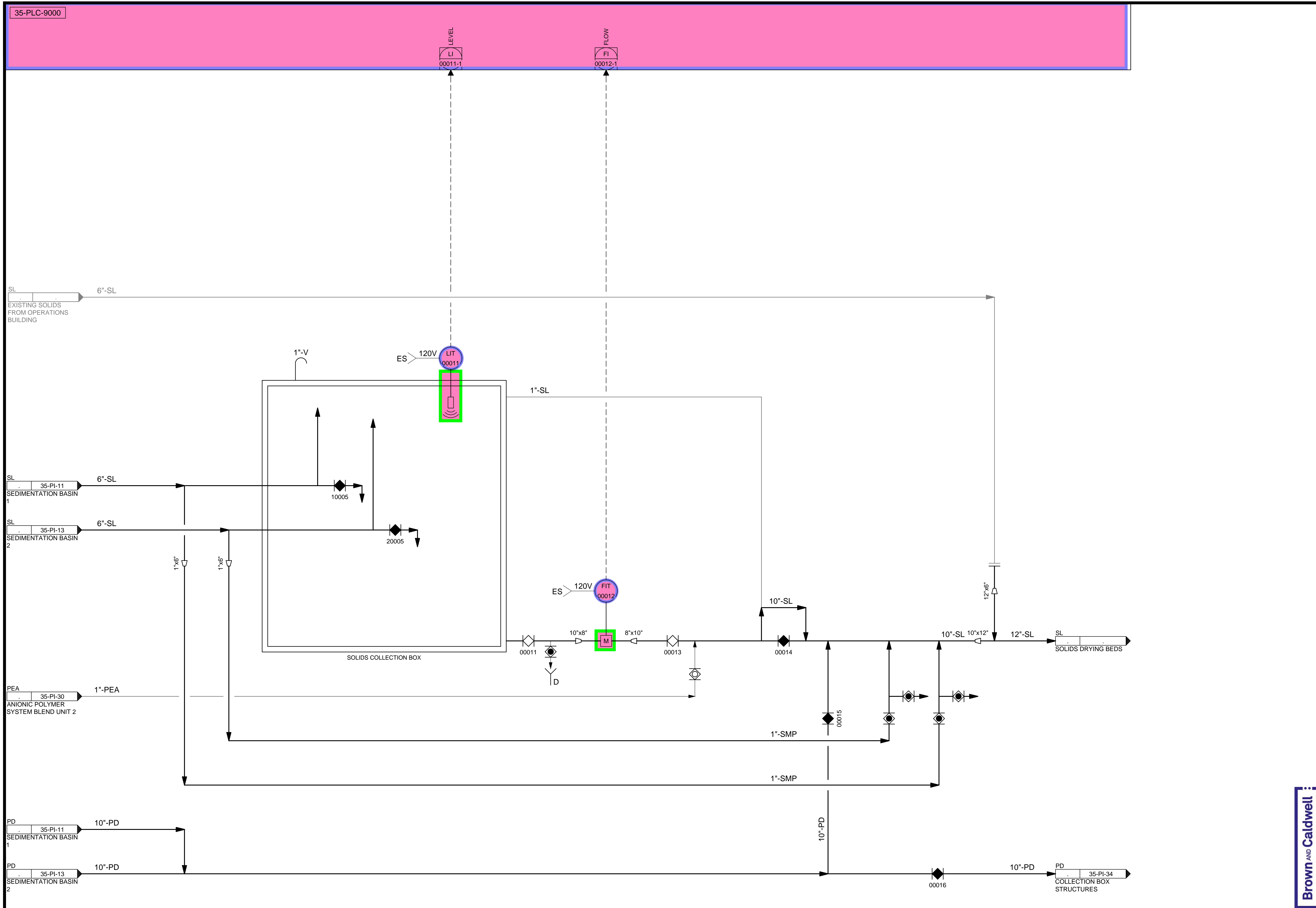

REVISIONS	
NO.	DATE
0	06/14/24
ISSUED FOR GUARANTEE MAXIMUM PRICE (GMP)	

SALT LAKE CITY DEPARTMENT OF PUBLIC UTILITIES
 CITY CREEK TREATMENT PLANT UPGRADES
 BRIC PACKAGE
**TREATMENT - SED BASINS
 SOLIDS COLLECTION BOX**

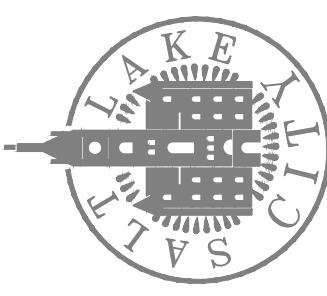

90% GMP

DRAWING NO.
35-PI-31

DESIGNED BY: BOTANI
 DRAWN BY: ALAPIERE
 CHECKED BY: ALAPIERE
 APPROVED BY: BOTANI
 DATE: JUNE 2024
 EWO NO: ---
 ACCOUNT NO: 512260079

SCALE: _____

VERIFY SCALE
 BAR IS ONE INCH ON ORIGINAL DRAWING

Brown and Caldwell

35-PLC-9000

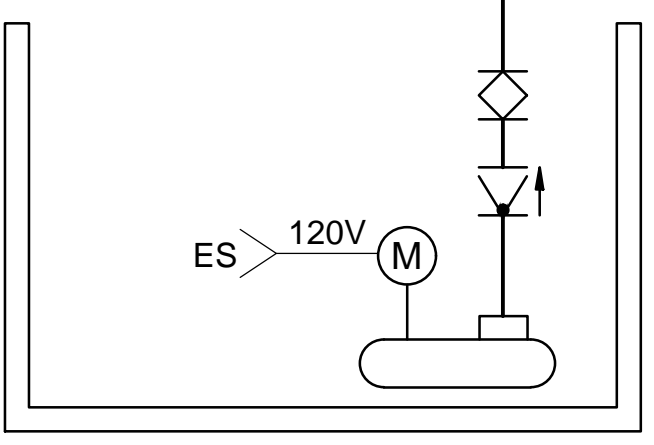
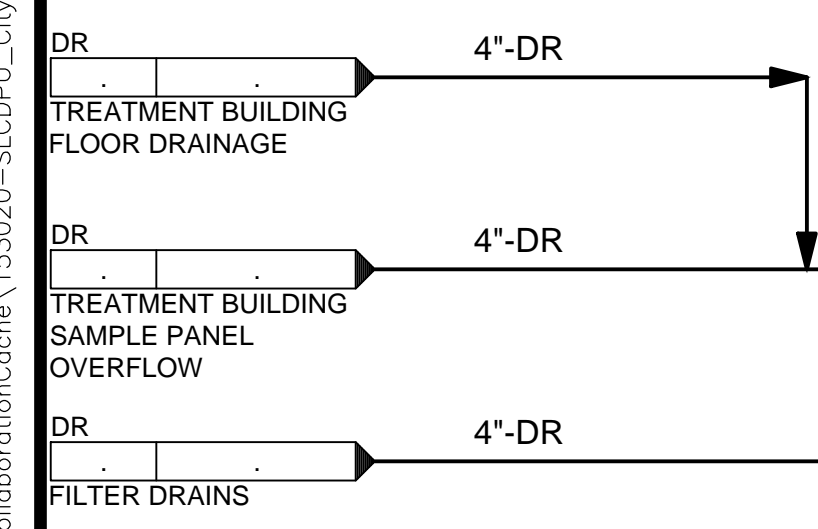
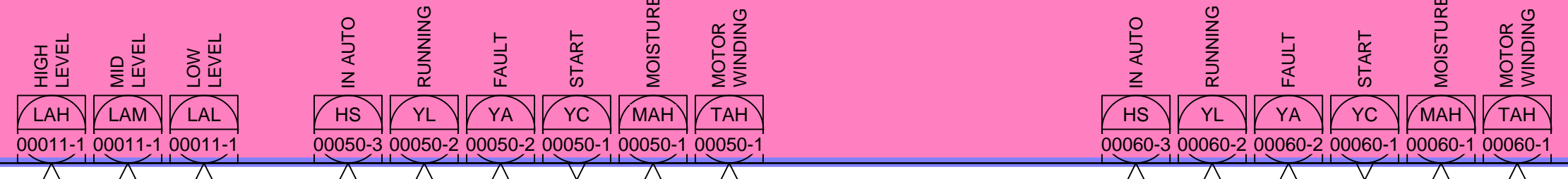

TREATMENT BUILDING RECYCLE PUMP 3
35-P-00090

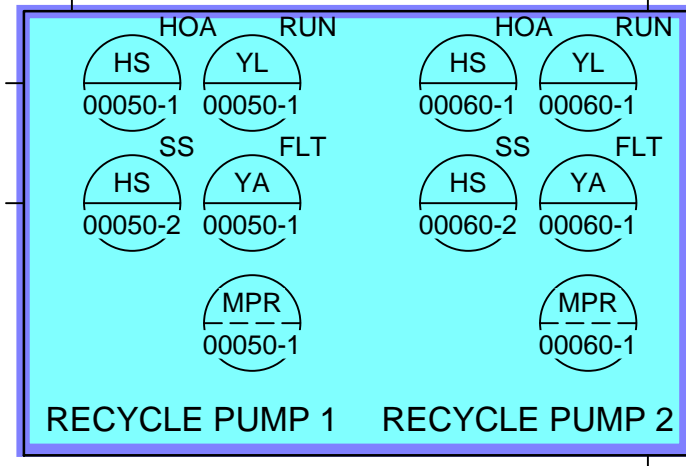
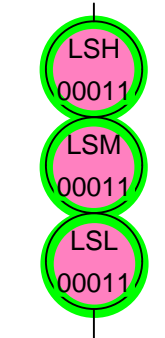

35-LCP-00050

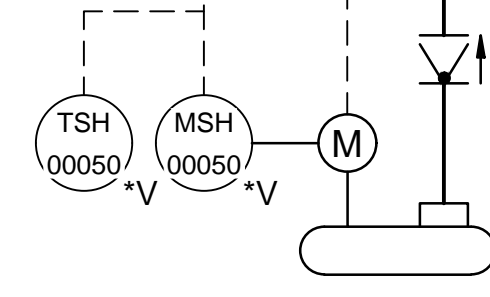

TREATMENT BUILDING RECYCLE PUMP 1
35-P-00050

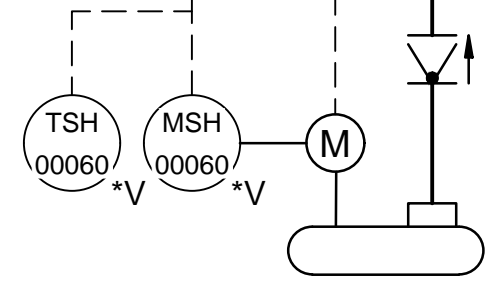

TREATMENT BUILDING RECYCLE PUMP 2
35-P-00060

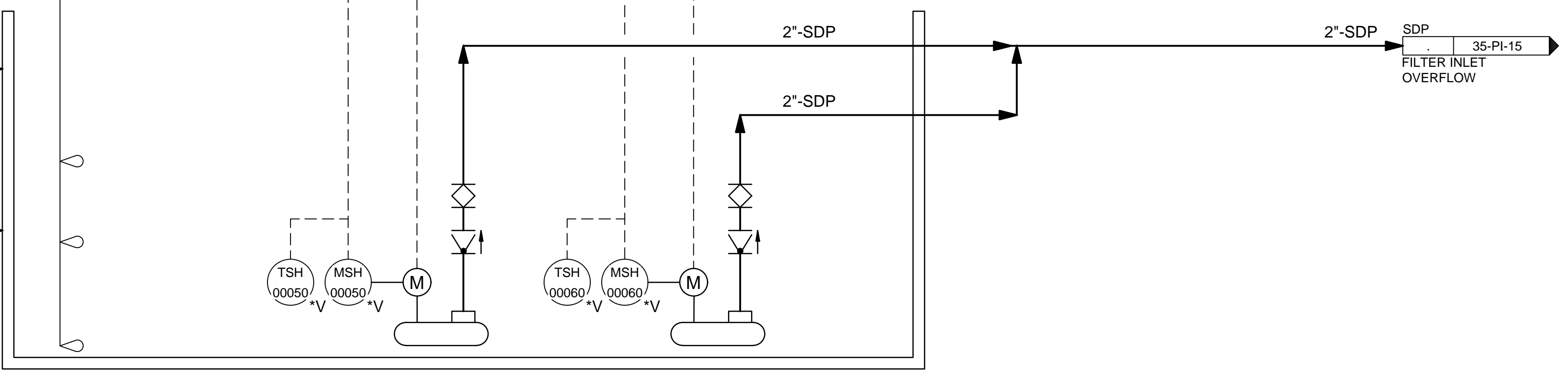

REVISIONS	
NO.	DATE
0	06/14/24

ISSUED FOR GUARANTEE MAXIMUM PRICE (GMP)

SALT LAKE CITY DEPARTMENT OF PUBLIC UTILITIES
 CITY CREEK TREATMENT PLANT UPGRADES
 BRIC PACKAGE
TREATMENT - RECYCLE PUMP STATION

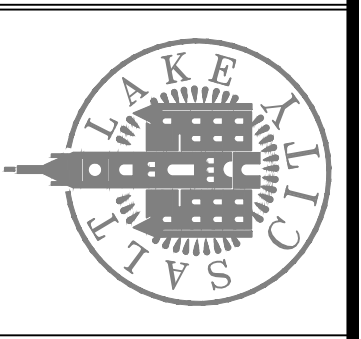

90% GMP

DRAWING NO.
35-PI-32

Brown and Caldwell

DESIGNED BY: BOTANI
 DRAWN BY: ALAPIERRE
 CHECKED BY: J.PAGENDARM
 APPROVED BY: BOTANI
 DATE: JUNE 2024
 EWO NO: ---
 ACCOUNT NO: 512260079

SCALE:
 AUTH. BY: BO
 MADE BY: BO

VERIFY SCALE
 BAR IS ONE INCH ON ORIGINAL DRAWING

C:\Users\alapierre\AppData\Local\Autodesk\AutoCAD Plant_3D\CollaborationCache\153020-SLICDPL_City_Creek_WTP-V2021\PID_DWG\35-PI-32.dwg Jun 12, 2024 -- 7:54pm

35-PLC-9000

C:\Users\alapiere\AppData\Local\Autodesk\AutoCAD Plant_3D\CollaborationCache\153020-SLICDPL_City_Creek_WTP-V2021\PID_DWG\35-PI-33.dwg Jun 24, 2024 -- 2:14pm

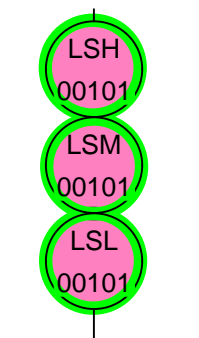
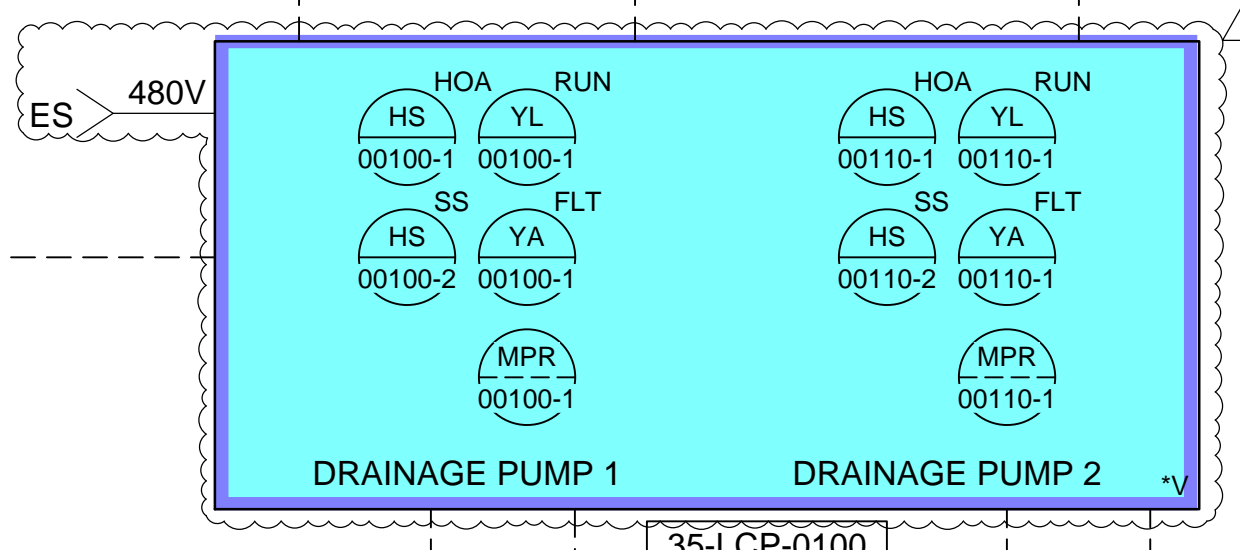
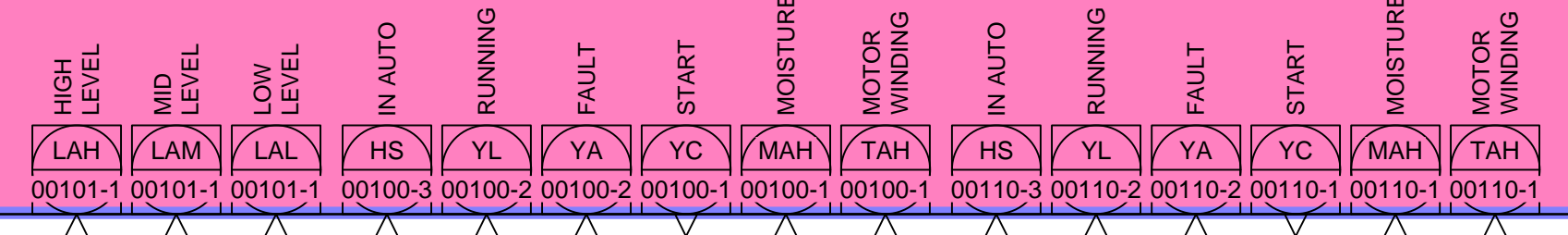
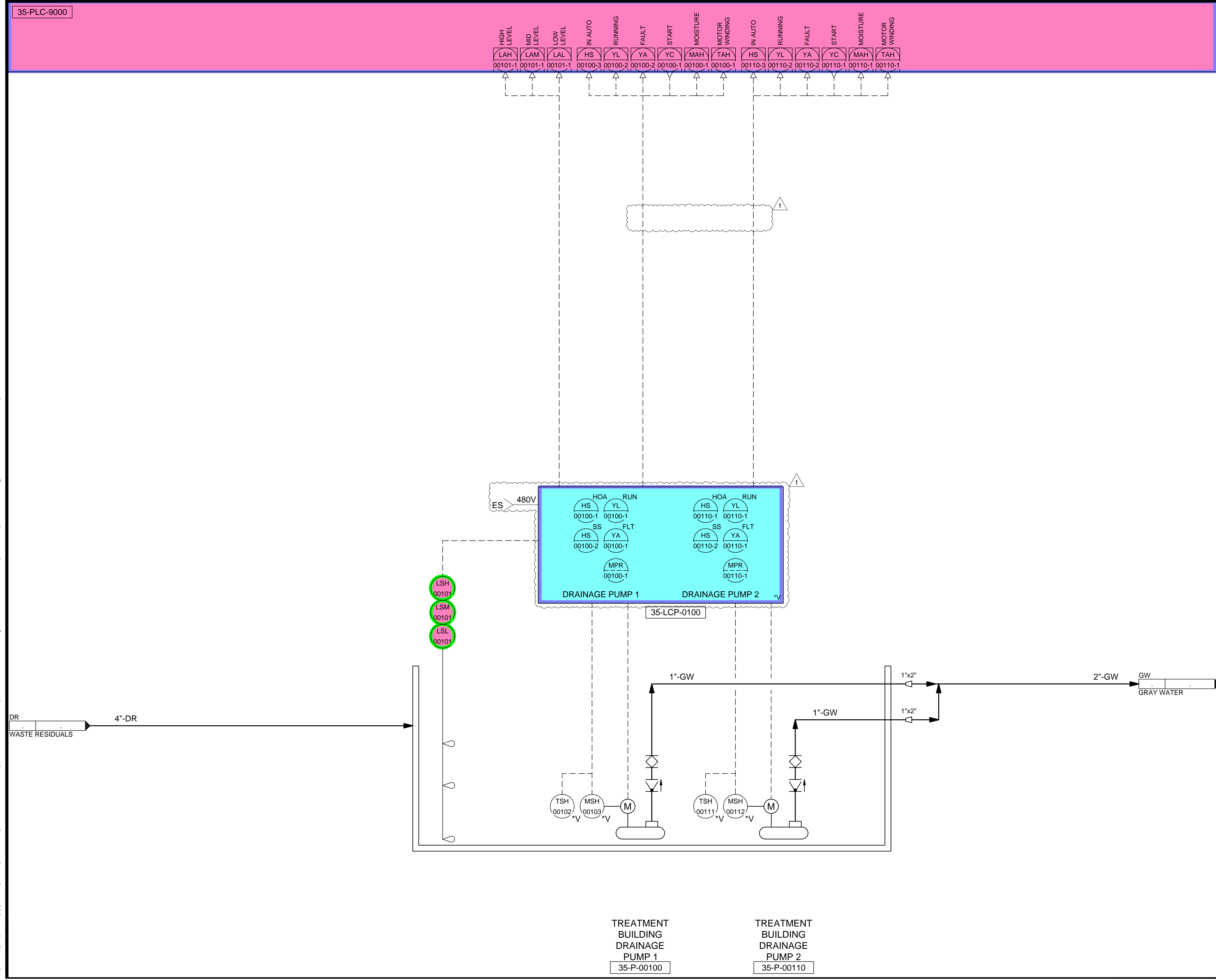

TREATMENT BUILDING DRAINAGE PUMP 1
35-P-00100

TREATMENT BUILDING DRAINAGE PUMP 2
35-P-00110

REVISIONS	
NO.	DATE
0	06/14/24
1	06/27/24

ISSUED FOR GUARANTEE MAXIMUM PRICE (GMP)
REVISED FOR GUARANTEED MAXIMUM PRICE (GMP)

SALT LAKE CITY DEPARTMENT OF PUBLIC UTILITIES
CITY CREEK TREATMENT PLANT UPGRADES
BRIC PACKAGE
TREATMENT - SUMP PUMPS

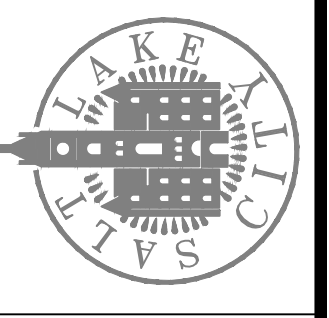

90% GMP

DRAWING NO.
35-PI-33

Brown and Caldwell

DESIGNED BY: BOTANI
DRAWN BY: ALAPIERE
CHECKED BY: ALPAGENDARM
APPROVED BY: BOTANI
DATE: JUNE 2024
EWO NO: --
ACCOUNT NO: 512260079

SCALE: _____

VERIFY SCALE
BAR IS ONE INCH ON ORIGINAL DRAWING

C:\Users\alopierre\AppData\Local\Autodesk\AutoCAD Plant 3D\CollaborationCache\153020-S\CD\PL City_Creek_WTP-V2021\PID_DWG\35-PI-34.dwg Jun 12, 2024 - 8:33pm

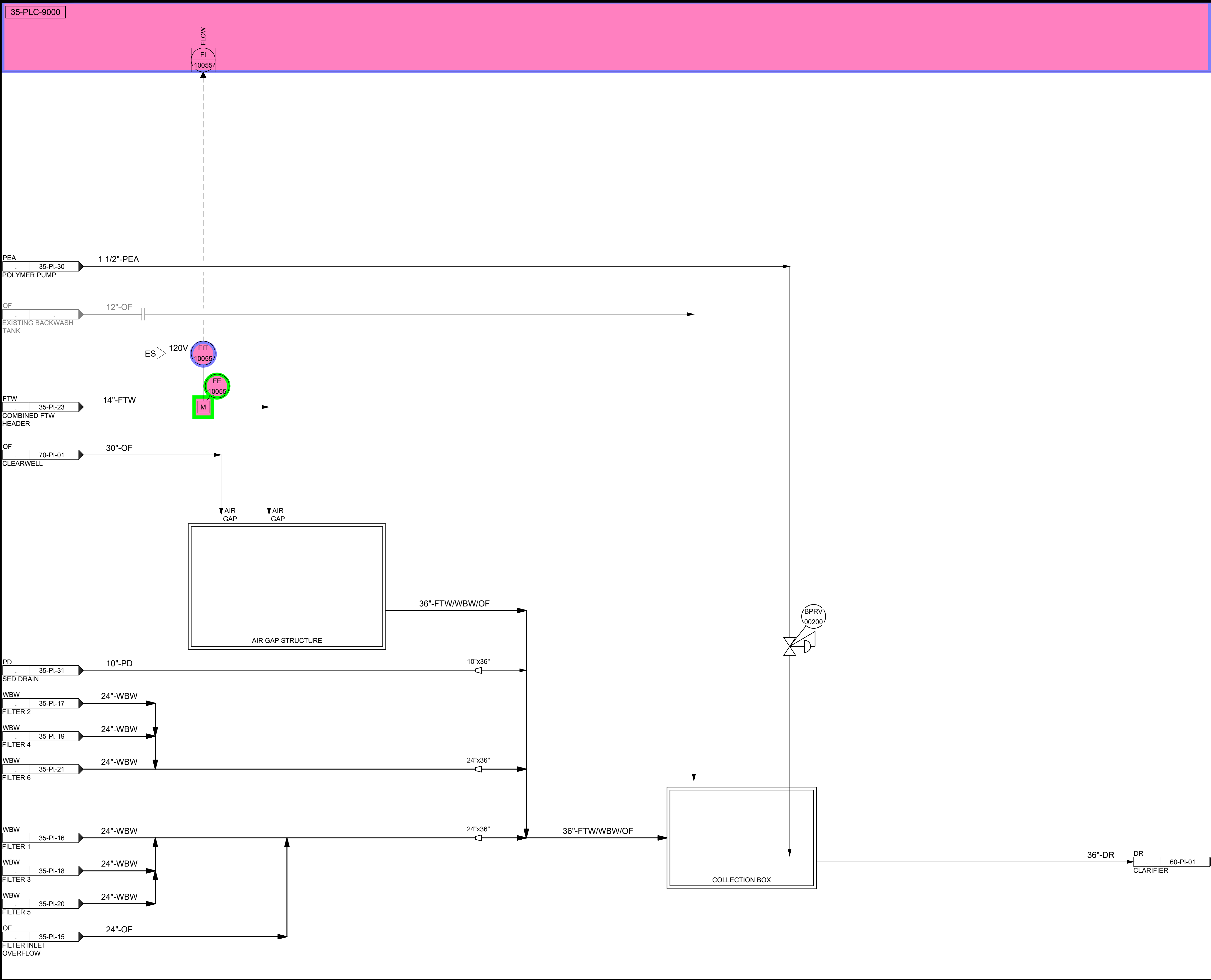

35-PLC-9000

DESIGNED BY: BOTANI
DRAWN BY: ALAPIERRE
CHECKED BY: J.PAGENDARM
APPROVED BY: BOTANI
DATE: JUNE 2024
EWO NO: 512260079
ACCOUNT NO: 512260079

SCALE: _____

VERIFY SCALE
BAR IS ONE INCH ON ORIGINAL DRAWING

NO.	DATE	REVISIONS
0	06/14/24	ISSUED FOR GUARANTEE MAXIMUM PRICE (GMP)

SALT LAKE CITY DEPARTMENT OF PUBLIC UTILITIES
CITY CREEK TREATMENT PLANT UPGRADES
BRIC PACKAGE
**TREATMENT - AIR GAP AND
COLLECTION BOX STRUCTURES**

90% GMP

DRAWING NO.
35-PI-34

Brown and Caldwell

C:\Users\alopierre\AppData\Local\Autodesk\AutoCAD Plant_3D\CollaborationCache\153020-SLICDPL_City_Creek_WTP-V2021\PID_DWG\60-PI-01.dwg Jun 12, 2024 8:47pm

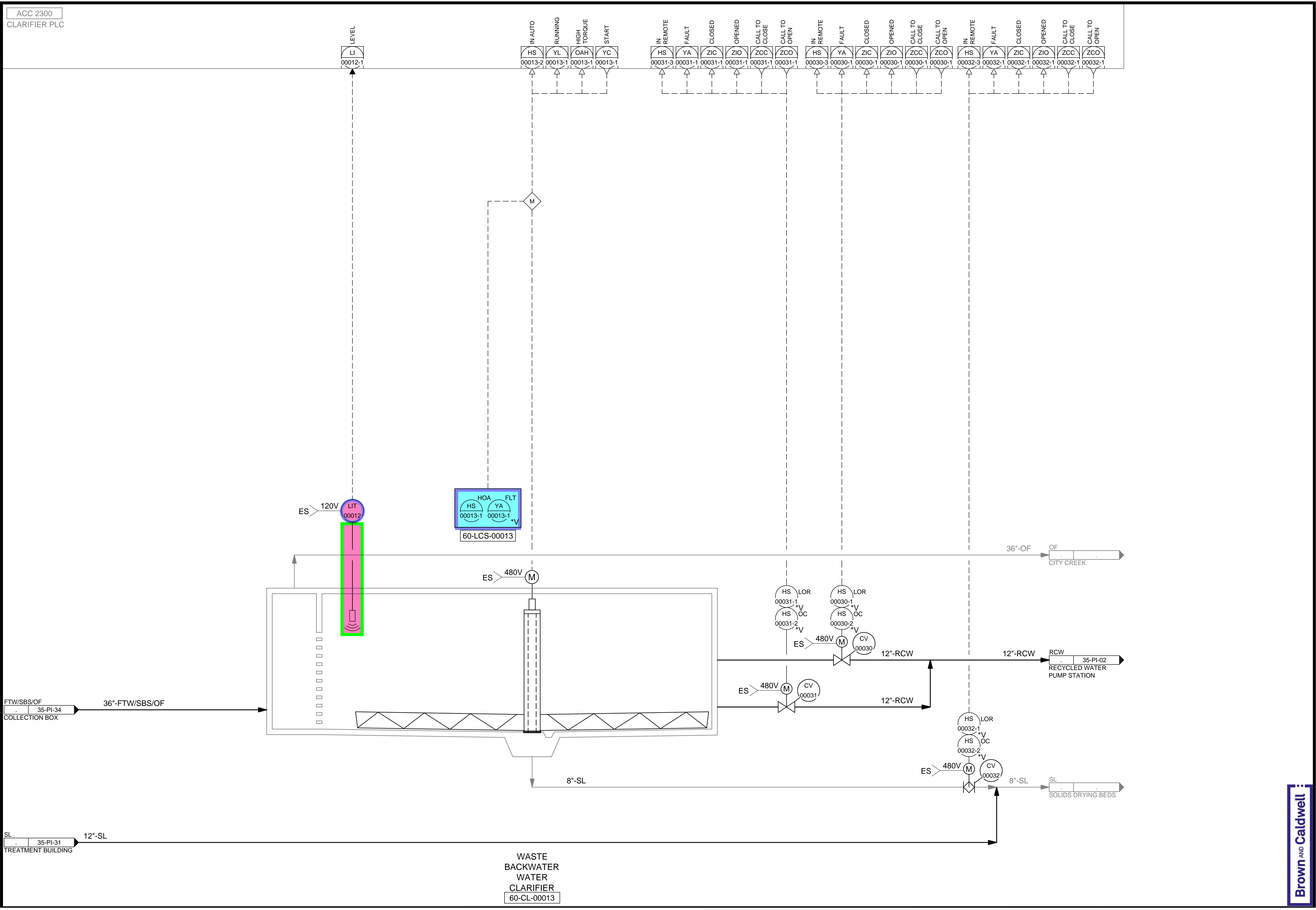

ACC 2300
CLARIFIER PLC

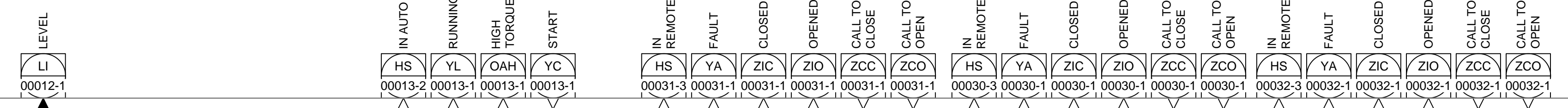

DESIGNED BY: BOTANI
 DRAWN BY: ALAPIERRE
 CHECKED BY: J.PAGENDARM
 APPROVED BY: BOTANI
 DATE: JUNE 2024
 EWO NO: ---
 ACCOUNT NO: 512260079

SCALE: _____

VERIFY SCALE
 BAR IS ONE INCH ON ORIGINAL DRAWING

NO.	DATE	REVISIONS	MADE BY	AUTH BY
0	06/14/24	ISSUED FOR GUARANTEE MAXIMUM PRICE (GMP)	BO	BO

SALT LAKE CITY DEPARTMENT OF PUBLIC UTILITIES
 CITY CREEK TREATMENT PLANT UPGRADES
 BRIC PACKAGE
WASTE BACKWASH WATER CLARIFIER

90% GMP

DRAWING NO.
60-PI-01

Brown and Caldwell

ACC 2300
CLARIFIER PLC

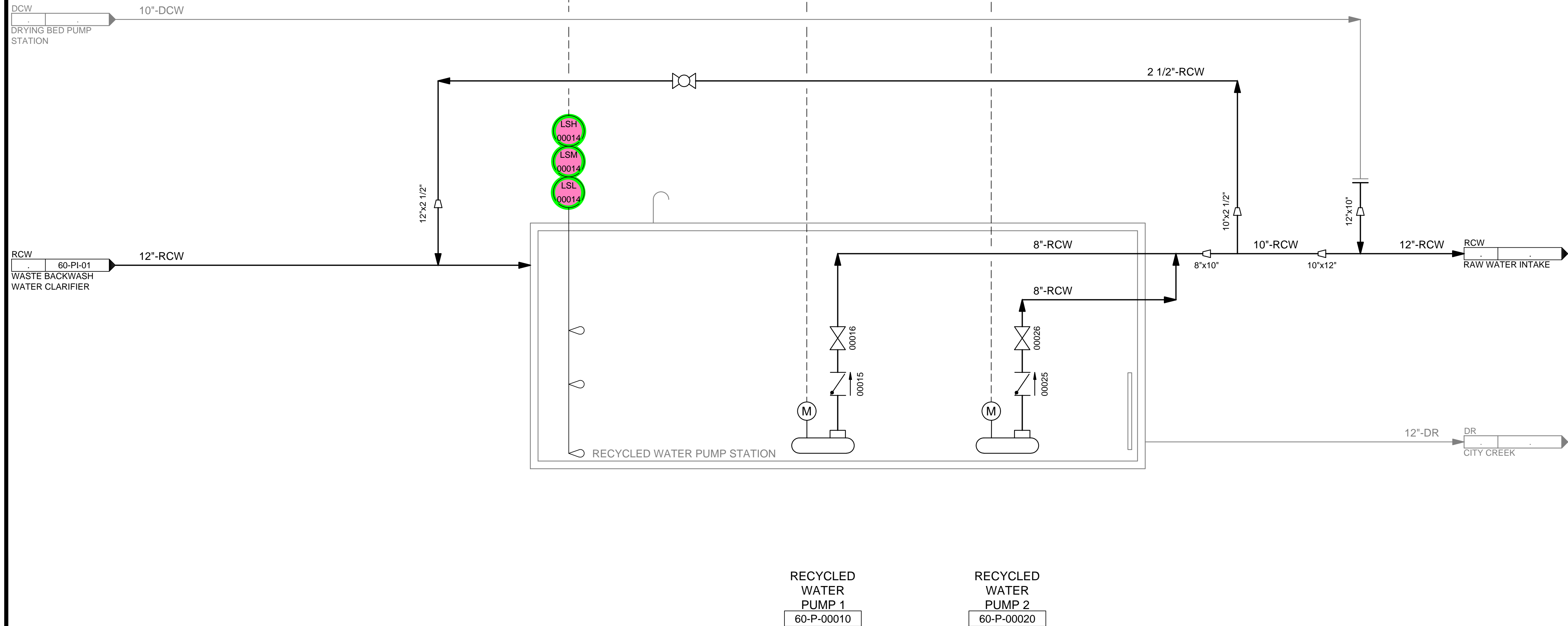
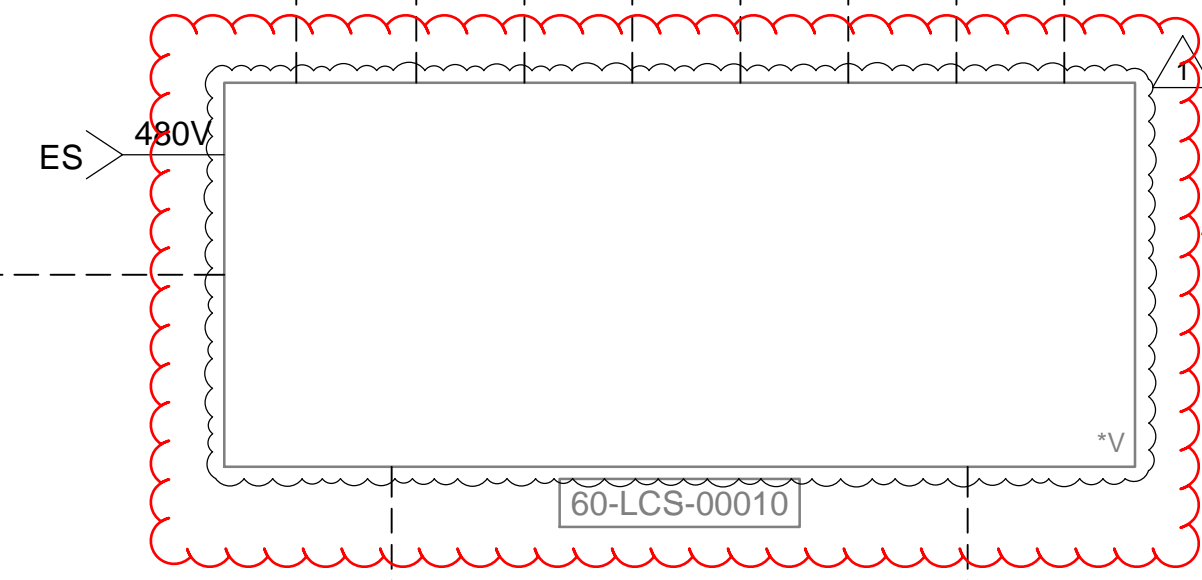
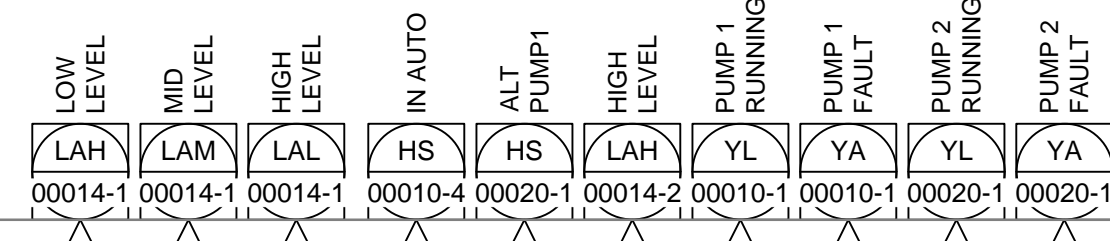

C:\Users\alapiere\AppData\Local\Autodesk\AutoCAD Plant_3D\CollaborationCache\153020-SLICDPL_City_Creek_WTP-V2021\PID_DWG\60-PI-02.dwg Jun 24, 2024 1:37pm

REVISIONS	
NO.	DATE
0	06/14/24
1	06/27/24

ISSUED FOR GUARANTEE MAXIMUM PRICE (GMP)
 REVISED FOR GUARANTEE MAXIMUM PRICE (GMP)

SALT LAKE CITY DEPARTMENT OF PUBLIC UTILITIES
 CITY CREEK TREATMENT PLANT UPGRADES
 BRIC PACKAGE
RECYCLED WATER PUMP STATION

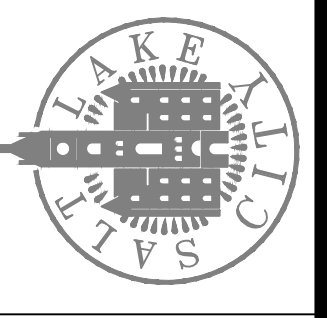

90% GMP

DRAWING NO.
60-PI-02

Brown and Caldwell

DESIGNED BY: BOTANI
 DRAWN BY: ALAPIERE
 CHECKED BY: ALPAGENDARM
 APPROVED BY: BOTANI
 DATE: JUNE 2024
 EMO NO: 512260079
 ACCOUNT NO: 512260079

SCALE:
VERIFY SCALE
 BAR IS ONE INCH ON ORIGINAL DRAWING

C:\Users\alapiere\AppData\Local\Autodesk\AutoCAD Plant 3D\CollaborationCache\153020-SLICDPL City_Creek_WTP-v2021\PID_DWG\70-PI-01.dwg Jun 12, 2024 - 8:51 pm

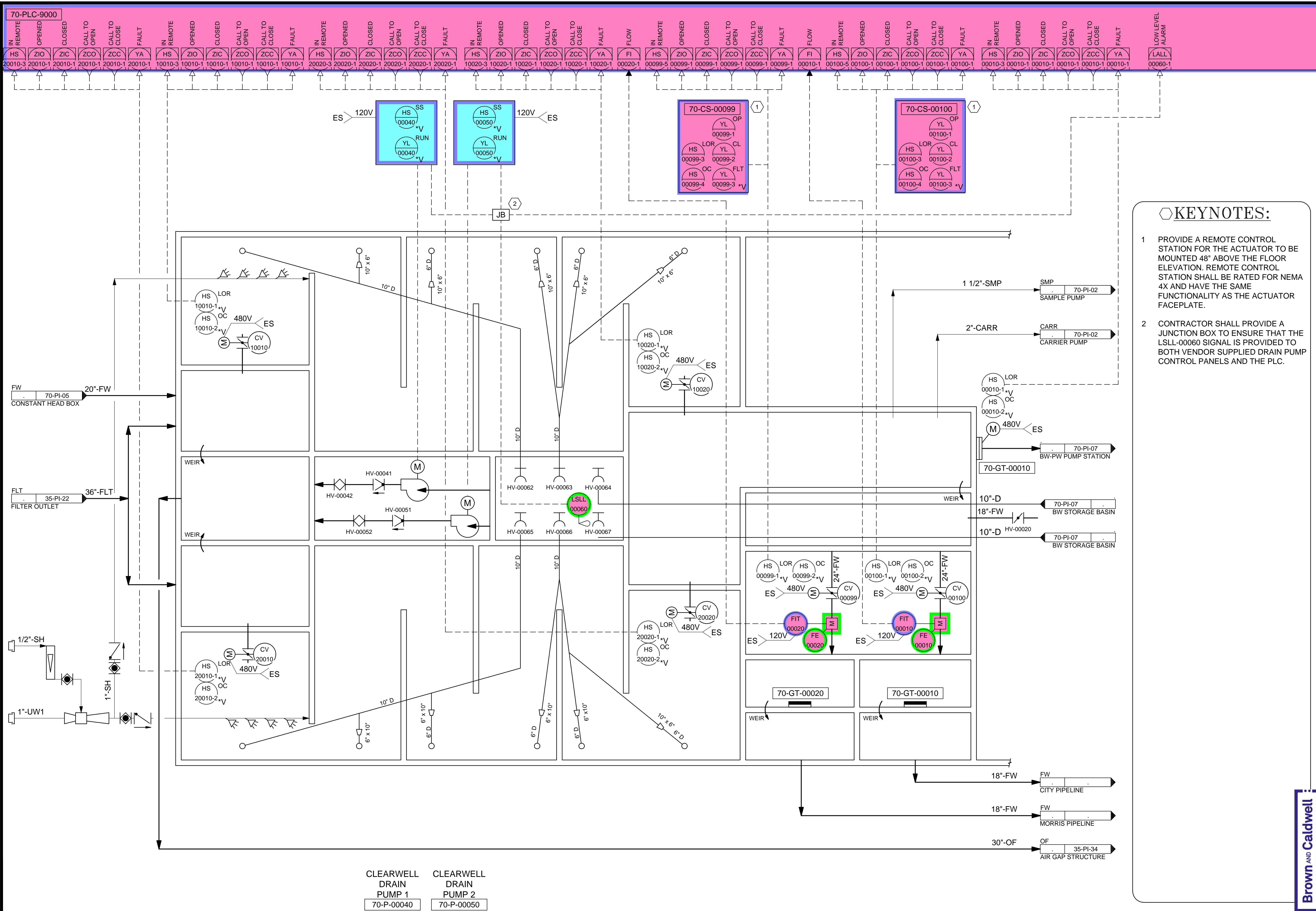

- KEYNOTES:**
- PROVIDE A REMOTE CONTROL STATION FOR THE ACTUATOR TO BE MOUNTED 48" ABOVE THE FLOOR ELEVATION. REMOTE CONTROL STATION SHALL BE RATED FOR NEMA 4X AND HAVE THE SAME FUNCTIONALITY AS THE ACTUATOR FACEPLATE.
 - CONTRACTOR SHALL PROVIDE A JUNCTION BOX TO ENSURE THAT THE LSL-00060 SIGNAL IS PROVIDED TO BOTH VENDOR SUPPLIED DRAIN PUMP CONTROL PANELS AND THE PLC.

DESIGNED BY: BOTANI
 DRAWN BY: ALAPIERE
 CHECKED BY: J.PAGENDARM
 APPROVED BY: BOTANI
 DATE: JUNE 2024
 EMO NO: ---
 ACCOUNT NO: 512260079

SCALE: ---

REVISIONS

NO.	DATE	BY	REVISION
0	06/14/24	ISSUED FOR GUARANTEE MAXIMUM PRICE (GMP)	

SALT LAKE CITY DEPARTMENT OF PUBLIC UTILITIES
 CITY CREEK TREATMENT PLANT UPGRADES
 BRIC PACKAGE
 CLEARWELLS

90% GMP

DRAWING NO. **70-PI-01**

Brown and Caldwell

C:\Users\Valopierre\AppData\Local\Autodesk\AutoCAD Plant 3D\Collaboration\Coche\153020-SLCDPLU_City_Creek_WTP-V2021\PID_DWG\70-PI-02.dwg Jun 12, 2024 - 8:53pm

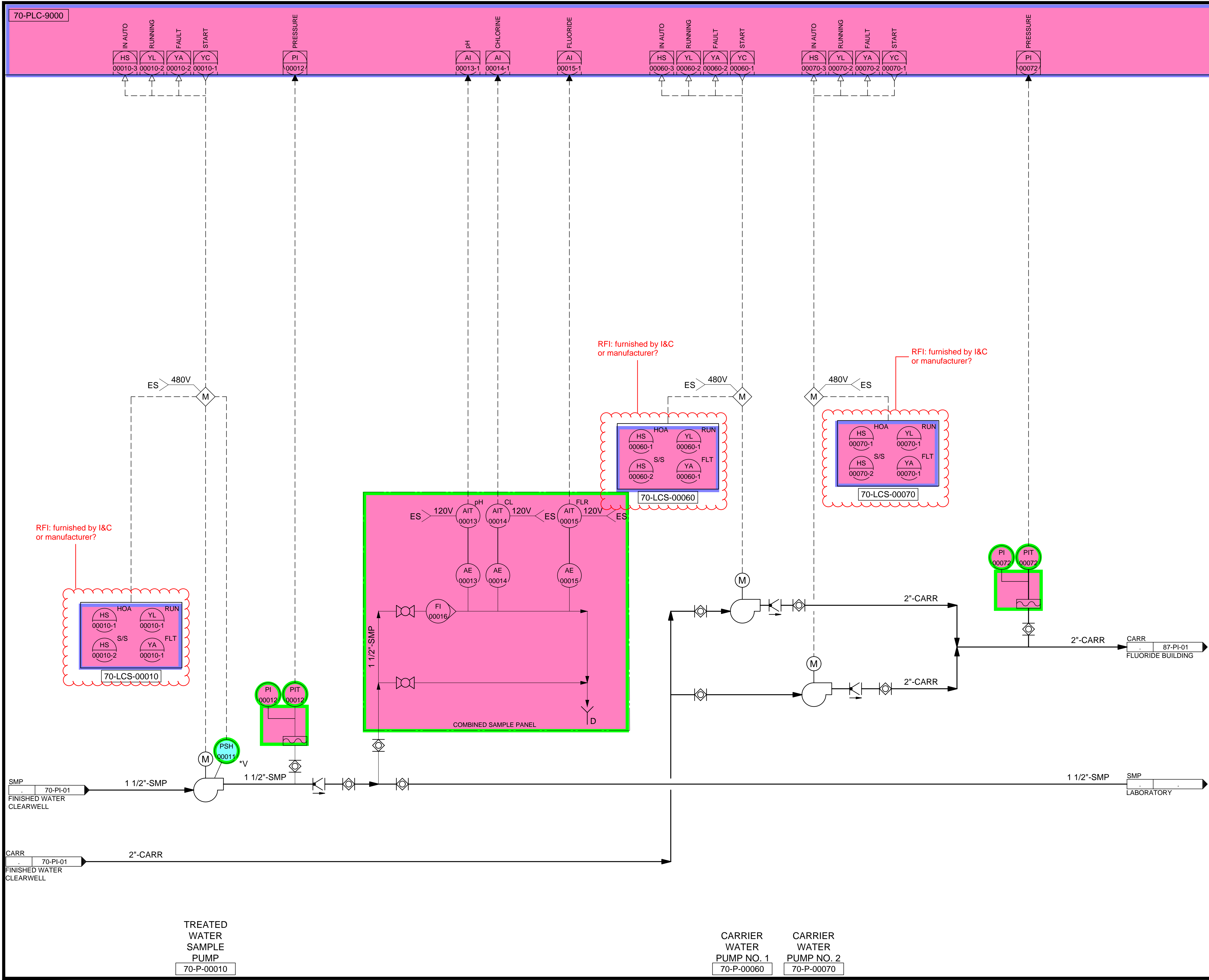

SALT LAKE CITY DEPARTMENT OF PUBLIC UTILITIES
 CITY CREEK TREATMENT PLANT UPGRADES
 BRIC PACKAGE
**CLEARWELL - CARRIER PUMPS
 AND SAMPLE PUMP**

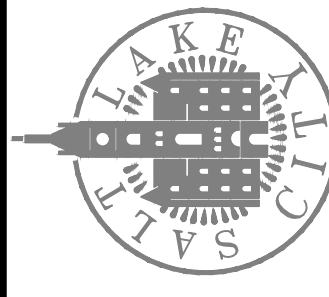

90% GMP

DRAWING NO.
70-PI-02

REVISIONS		DATE	NO.	ISSUED FOR	GUARANTEE	MAXIMUM PRICE (GMP)
0	06/14/24					

DESIGNED BY:	B. OTANI
DRAWN BY:	A. LAPIERRE
CHECKED BY:	M. PAGENDARM
APPROVED BY:	B. OTANI
DATE:	JUNE 2024
EWO NO.:	---
ACCOUNT NO.:	512260079

SCALE: _____

VERIFY SCALE
 BAR IS ONE INCH ON ORIGINAL DRAWING

Brown and Caldwell

C:\Users\alapiere\AppData\Local\Autodesk\AutoCAD Plant_3D\CollaborationCache\153020-SLICD\P\L_City_Creek_WTP-v2021\PID_DWG\70-PI-03.dwg Jun 12, 2024 8:55pm

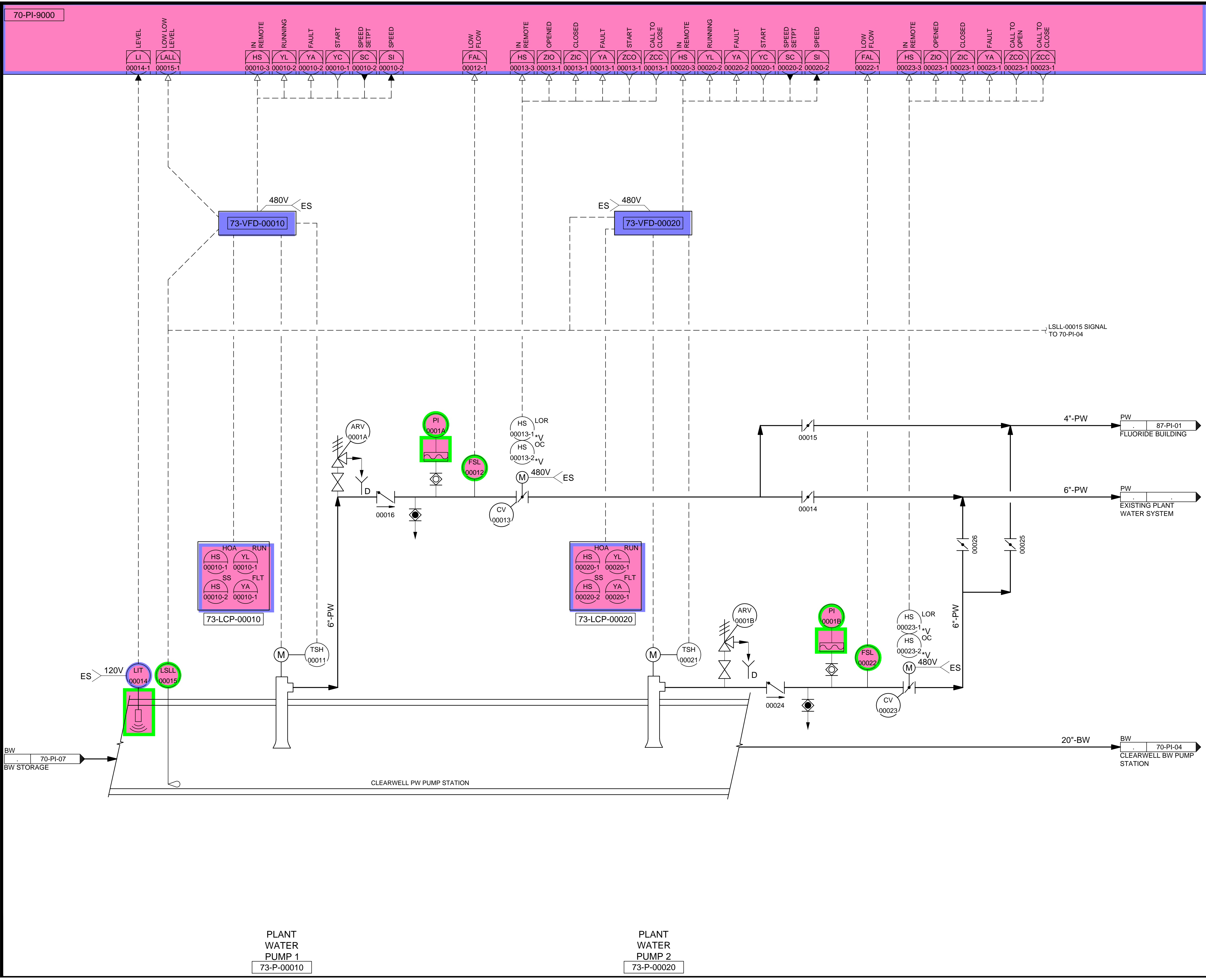

70-PI-9000																												
LEVEL	LOW LOW LEVEL	IN REMOTE	RUNNING	FAULT	START	SPEED SETPT	SPEED	LOW FLOW	IN REMOTE	OPENED	CLOSED	FAULT	START	CALL TO CLOSE	IN REMOTE	RUNNING	FAULT	START	SPEED SETPT	SPEED	LOW FLOW	IN REMOTE	OPENED	CLOSED	FAULT	CALL TO OPEN	CALL TO CLOSE	
LI	LALL	HS	YL	YA	YC	SC	SI	FAL	HS	ZIO	ZIC	YA	ZCO	ZCC	HS	YL	YA	YC	SC	SI	FAL	HS	ZIO	ZIC	YA	ZCO	ZCC	
00014-1	00015-1	00010-3	00010-2	00010-2	00010-1	00010-2	00010-2	00012-1	00013-3	00013-1	00013-1	00013-1	00013-1	00013-1	00020-3	00020-2	00020-2	00020-1	00020-2	00020-2	00022-1	00023-3	00023-1	00023-1	00023-1	00023-1	00023-1	00023-1

DESIGNED BY: BOTANI	SCALE:
DRAWN BY: ALAPIERE	
CHECKED BY: J.PAGENDARM	
APPROVED BY: BOTANI	
DATE: JUNE 2024	
EWO NO: 512260079	
ACCOUNT NO: 512260079	

NO.	DATE	REVISIONS
0	06/14/24	ISSUED FOR GUARANTEE MAXIMUM PRICE (GMP)

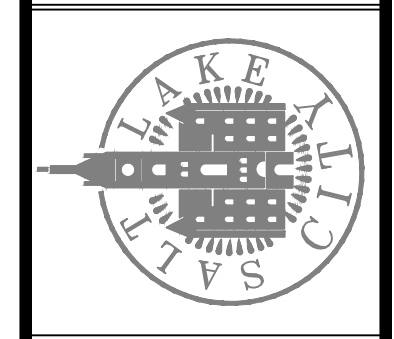

90% GMP

DRAWING NO.
70-PI-03

Brown and Caldwell

CLEARWELL - PW PUMP STATION

C:\Users\alapiere\AppData\Local\Autodesk\AutoCAD Plant_3D\CollaborationCache\153020-SLICD\PUL_City_Creek_WTP-V2021\PID_DWG\70-PI-04.dwg Jun 12, 2024 -- 9:05pm

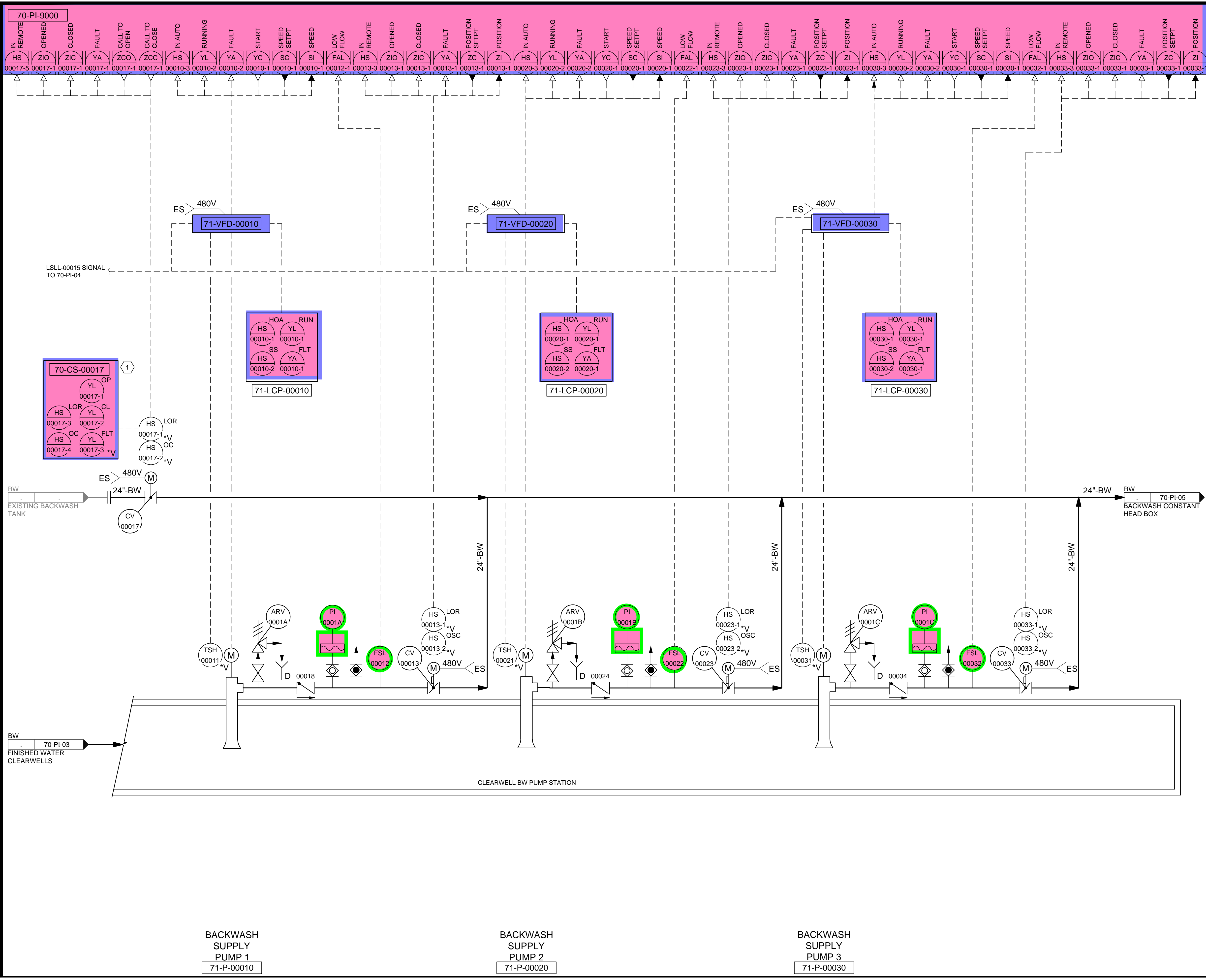

KEYNOTES:

- 1 PROVIDE A REMOTE CONTROL STATION FOR THE ACTUATOR TO BE MOUNTED 48" ABOVE THE FLOOR ELEVATION. REMOTE CONTROL STATION SHALL BE RATED FOR NEMA 4X AND HAVE THE SAME FUNCTIONALITY AS THE ACTUATOR FACEPLATE.

DESIGNED BY: BOTANI		SCALE:	
DRAWN BY: ALAPIERE		AUTH. BY: BO	
CHECKED BY: J.PAGENDARM		MADE BY: BO	
APPROVED BY: BOTANI		DATE: JUNE 2024	
EWO NO: 512260079		ACCOUNT NO: 512260079	

REVISIONS

NO.	DATE	ISSUED FOR	GUARANTEE	MAXIMUM PRICE (GMP)
0	06/14/24			

SALT LAKE CITY DEPARTMENT OF PUBLIC UTILITIES
CITY CREEK TREATMENT PLANT UPGRADES
BRIC PACKAGE
CLEARWELL - BACKWASH SUPPLY PUMP STATION

90% GMP

DRAWING NO. **70-PI-04**

Brown and Caldwell

VERIFY SCALE
BAR IS ONE INCH ON ORIGINAL DRAWING

C:\Users\alapiere\AppData\Local\Autodesk\AutoCAD Plant_3D\CollaborationCache\153020-SLICDPL_City_Creek_WTP-V2021\PID_DWG\70-PI-05.dwg Jun 12, 2024 -- 9:03pm

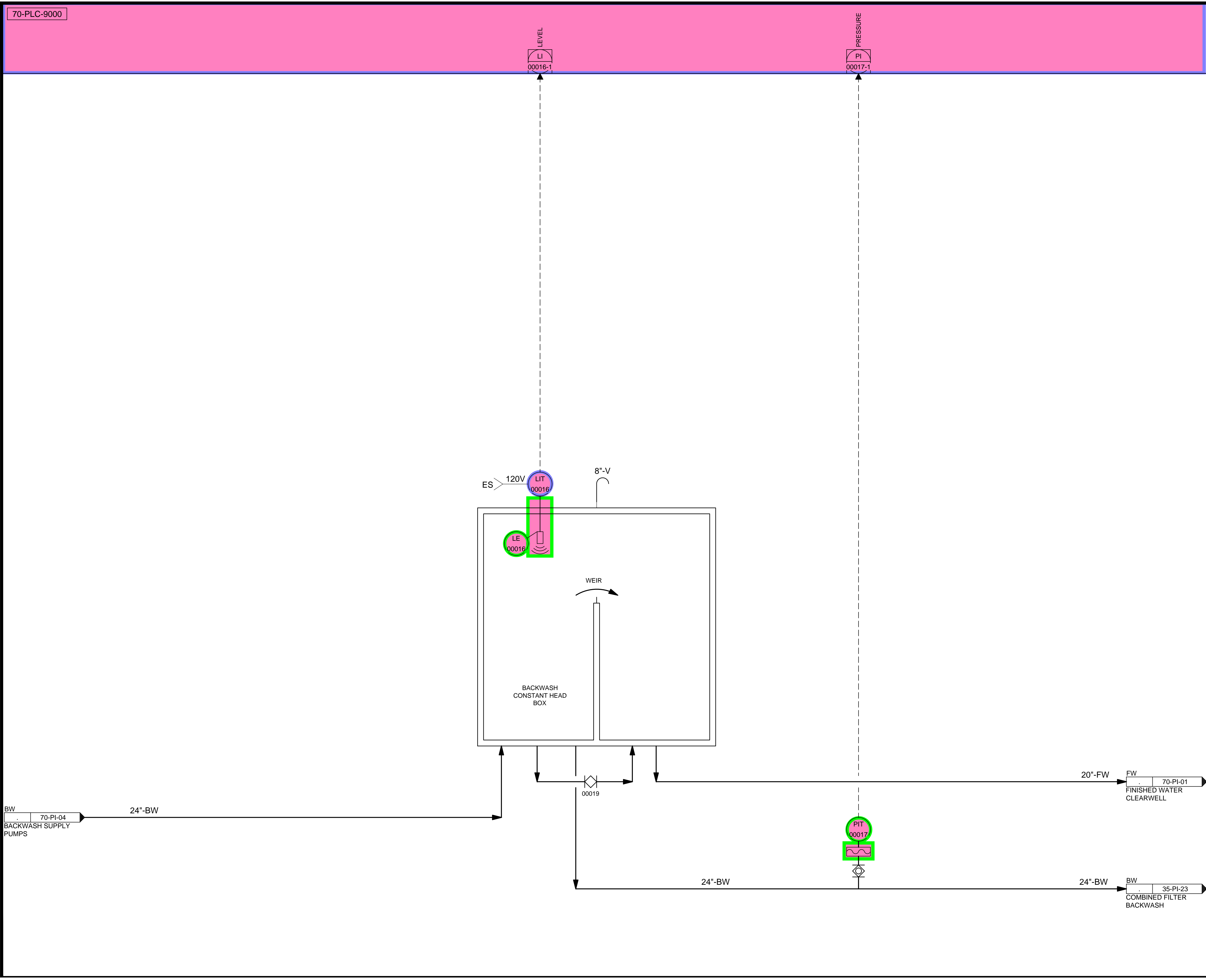

70-PLC-9000

LEVEL
L
00016-1

PRESSURE
PI
00017-1

BW 70-PI-04 BACKWASH SUPPLY PUMPS

24"-BW

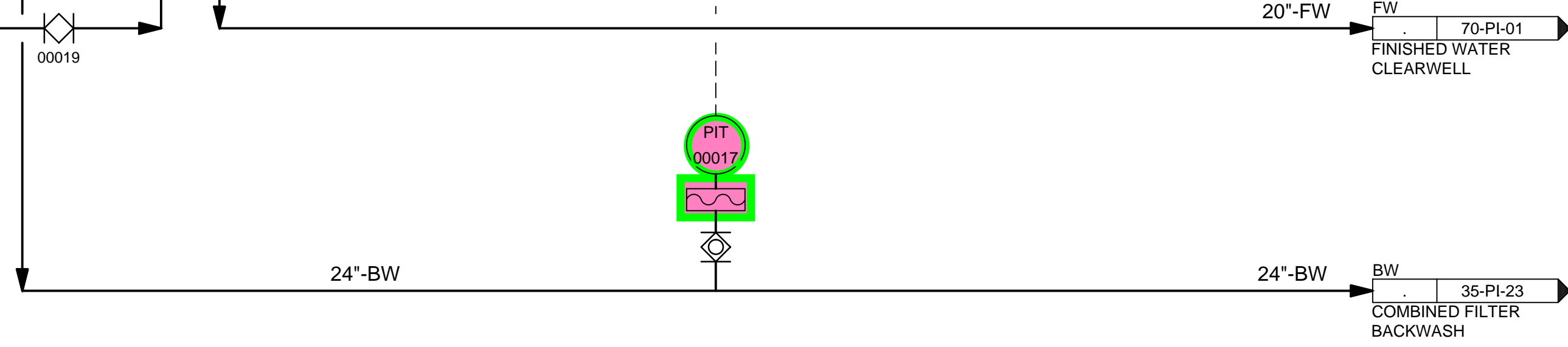
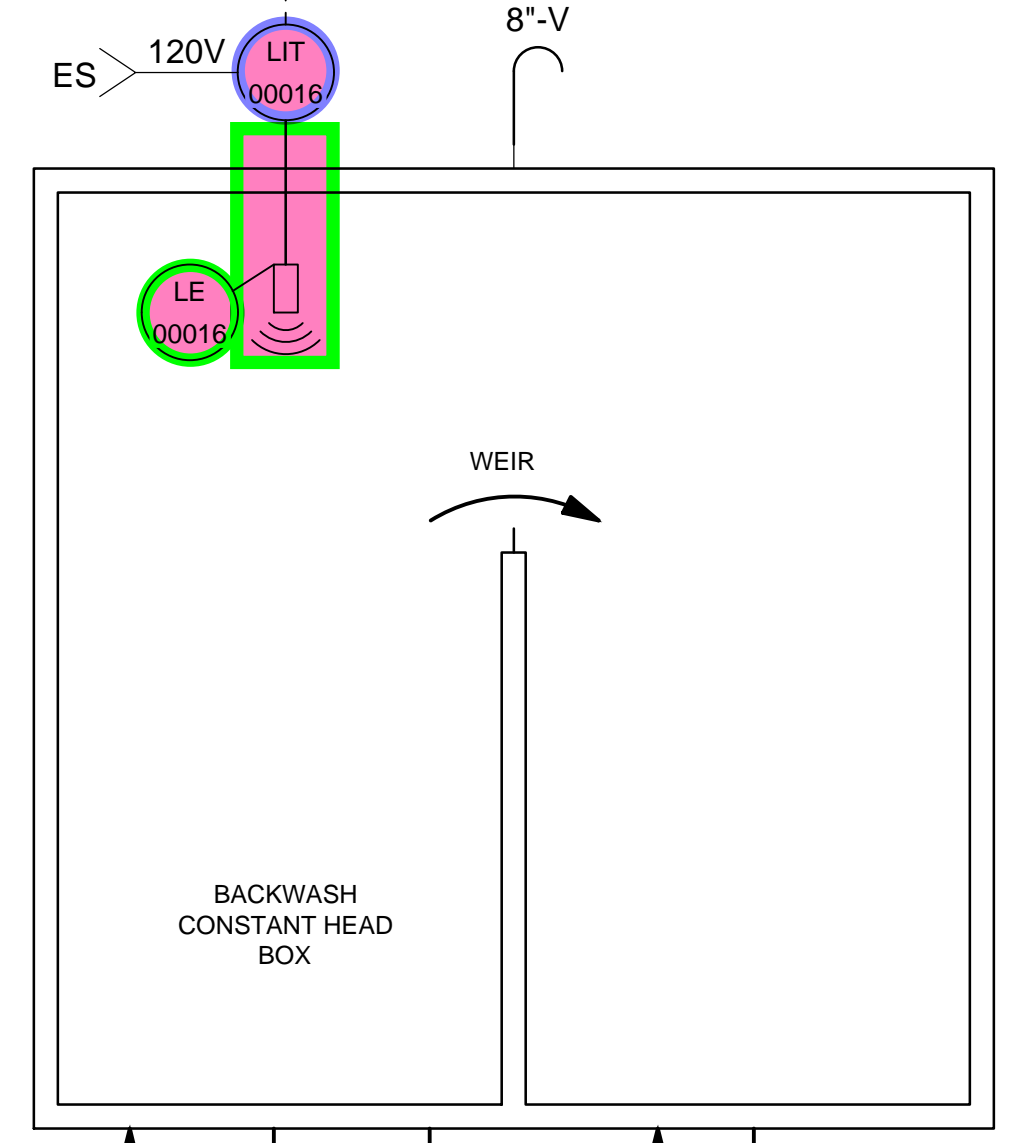

Brown and Caldwell

REVISIONS	
NO.	DATE
0	06/14/24
ISSUED FOR GUARANTEE MAXIMUM PRICE (GMP)	
AUTH. BY	BO
MADE BY	BO
DESIGNED BY:	BOTANI
DRAWN BY:	ALAPIERE
CHECKED BY:	M.PAGENDARM
APPROVED BY:	BOTANI
DATE:	JUNE 2024
EWO NO.:	---
ACCOUNT NO.:	512260079

SALT LAKE CITY DEPARTMENT OF PUBLIC UTILITIES
 CITY CREEK TREATMENT PLANT UPGRADES
 BRIC PACKAGE
**CLEARWELL - BACKWASH
 CONSTANT HEAD STRUCTURE**

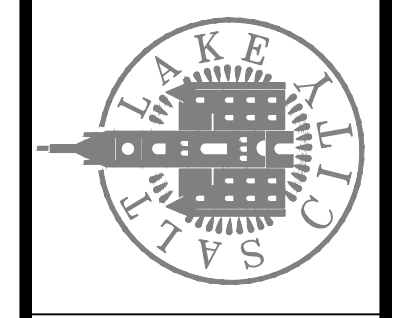

90% GMP

DRAWING NO.
70-PI-05

SCALE:

VERIFY SCALE
 BAR IS ONE INCH ON ORIGINAL DRAWING

C:\Users\alapierre\AppData\Local\Autodesk\AutoCAD Plant_3D\CollaborationCache\153020-SLICDPL_City_Creek_WTP-v2021\PID_DWG\70-PI-06.dwg Jun 24, 2024 -- 9:58am

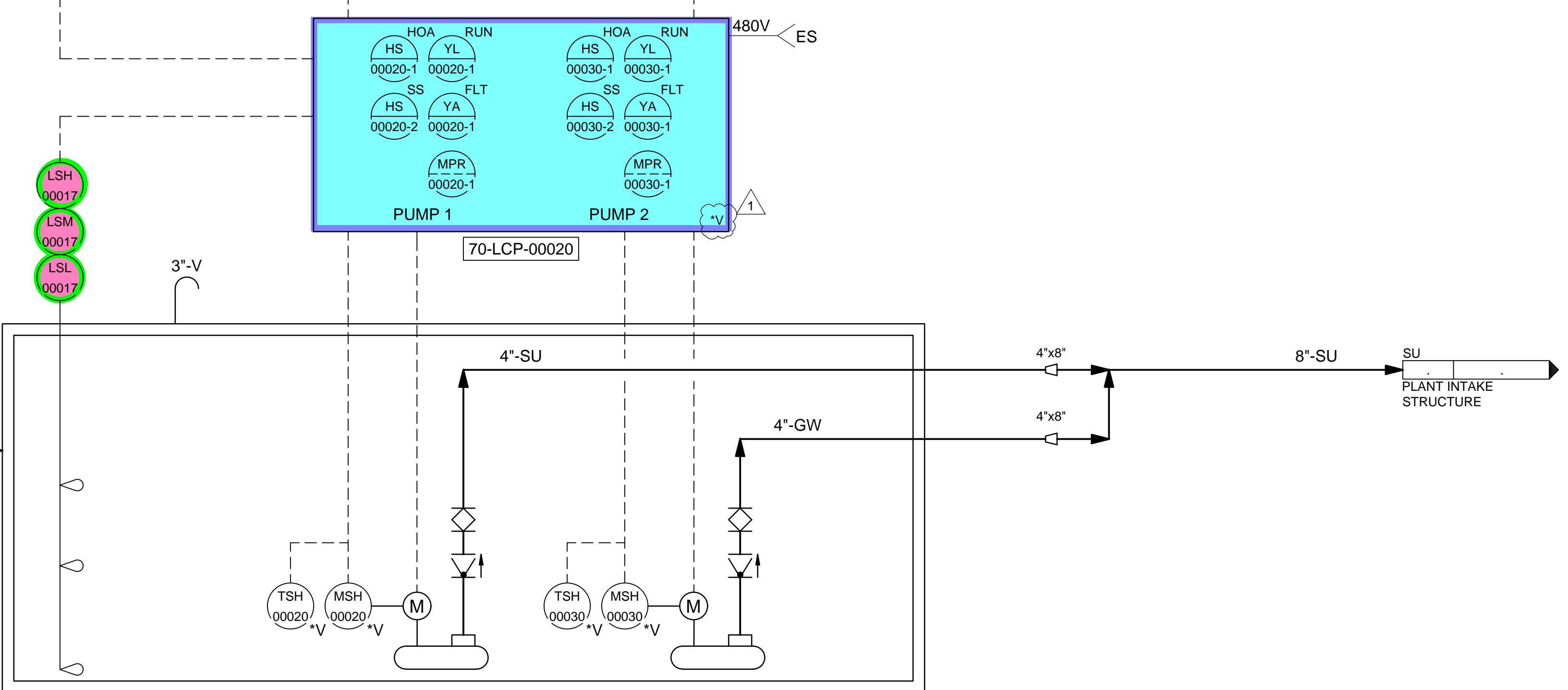

SU
TREATMENT BUILDING
STRUCTURAL
UNDERDRAIN SYSTEM

STRUCTURAL
UNDERDRAIN
PUMP
STATION
PUMP 1
70-P-00020

STRUCTURAL
UNDERDRAIN
PUMP
STATION
PUMP 2
70-P-00030

Brown and Caldwell

REVISIONS	
NO.	DATE
0	06/14/24
1	06/27/24

DESIGNED BY: BOTANI
DRAWN BY: ALAPIERRE
CHECKED BY: ALPAGENDARM
APPROVED BY: BOTANI
DATE: JUNE 2024
EWO NO: 512260079
ACCOUNT NO: 512260079

SALT LAKE CITY DEPARTMENT OF PUBLIC UTILITIES
CITY CREEK TREATMENT PLANT UPGRADES
BRIC PACKAGE
**CLEARWELL - STRUCTURAL
UNDERDRAIN PUMP STATION**

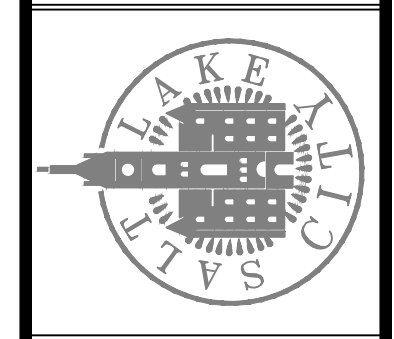

90% GMP

DRAWING NO.
70-PI-06

SCALE:
VERIFY SCALE
BAR IS ONE INCH ON ORIGINAL DRAWING

C:\Users\alopierre\AppData\Local\Autodesk\AutoCAD Plant 3D\Collaboration\Coche\153020-SLCDPLU_City_Creek_WTP-V2021\PID_DWG\70-PI-07.dwg Jun 12, 2024 - 9:00pm

70-PLC-9000

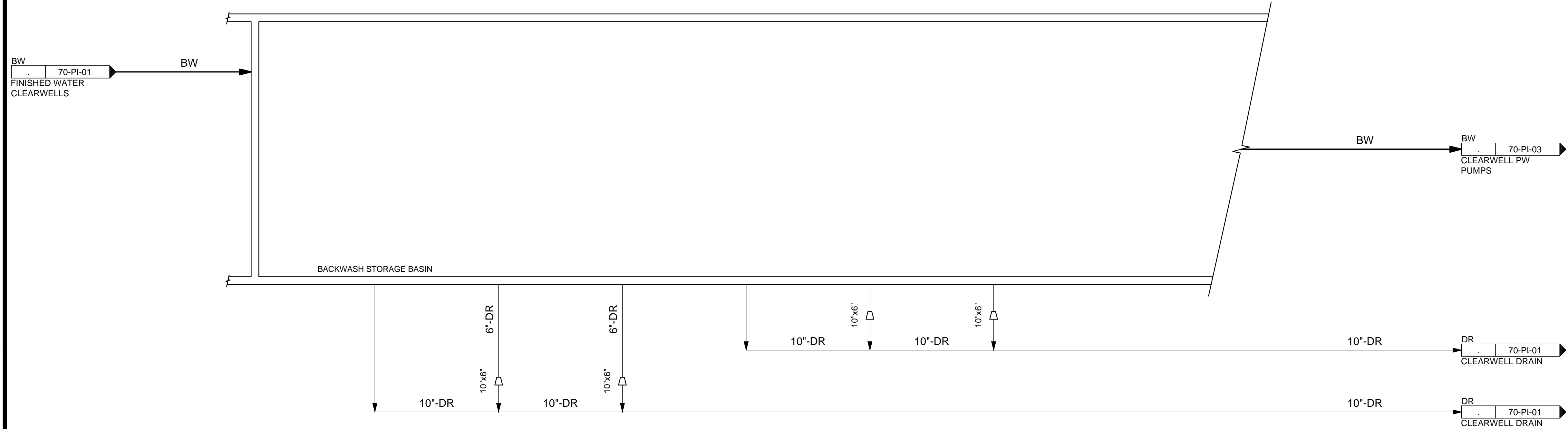

Brown and Caldwell

SALT LAKE CITY DEPARTMENT OF PUBLIC UTILITIES
 CITY CREEK TREATMENT PLANT UPGRADES
 BRIC PACKAGE
**CLEARWELL - BW STORAGE
 BASIN**

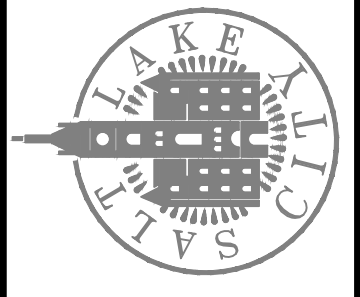

90% GMP

DRAWING NO.
70-PI-07

REVISIONS

NO.	DATE	ISSUED FOR	GUARANTEE	MAXIMUM PRICE (GMP)	MADE BY	BO	AUTH BY	BO
0	06/14/24	ISSUED FOR	GUARANTEE	MAXIMUM PRICE (GMP)	BO	BO	BO	BO

DESIGNED BY: B.GTANI
 DRAWN BY: A.LAPIERRE
 CHECKED BY: M.PAGENDARM
 APPROVED BY: B.GTANI
 DATE: JUNE 2024
 EWO NO: --
 ACCOUNT NO: 512260079

SCALE: _____

VERIFY SCALE
 BAR IS ONE INCH ON ORIGINAL DRAWING

C:\Users\alapiere\AppData\Local\Autodesk\AutoCAD Plant_3D\CollaborationCache\153020-SLICDPL_City_Creek_WTP-V2021\PID_DWG\87-PI-01.dwg Jun 12, 2024 - 8:58pm

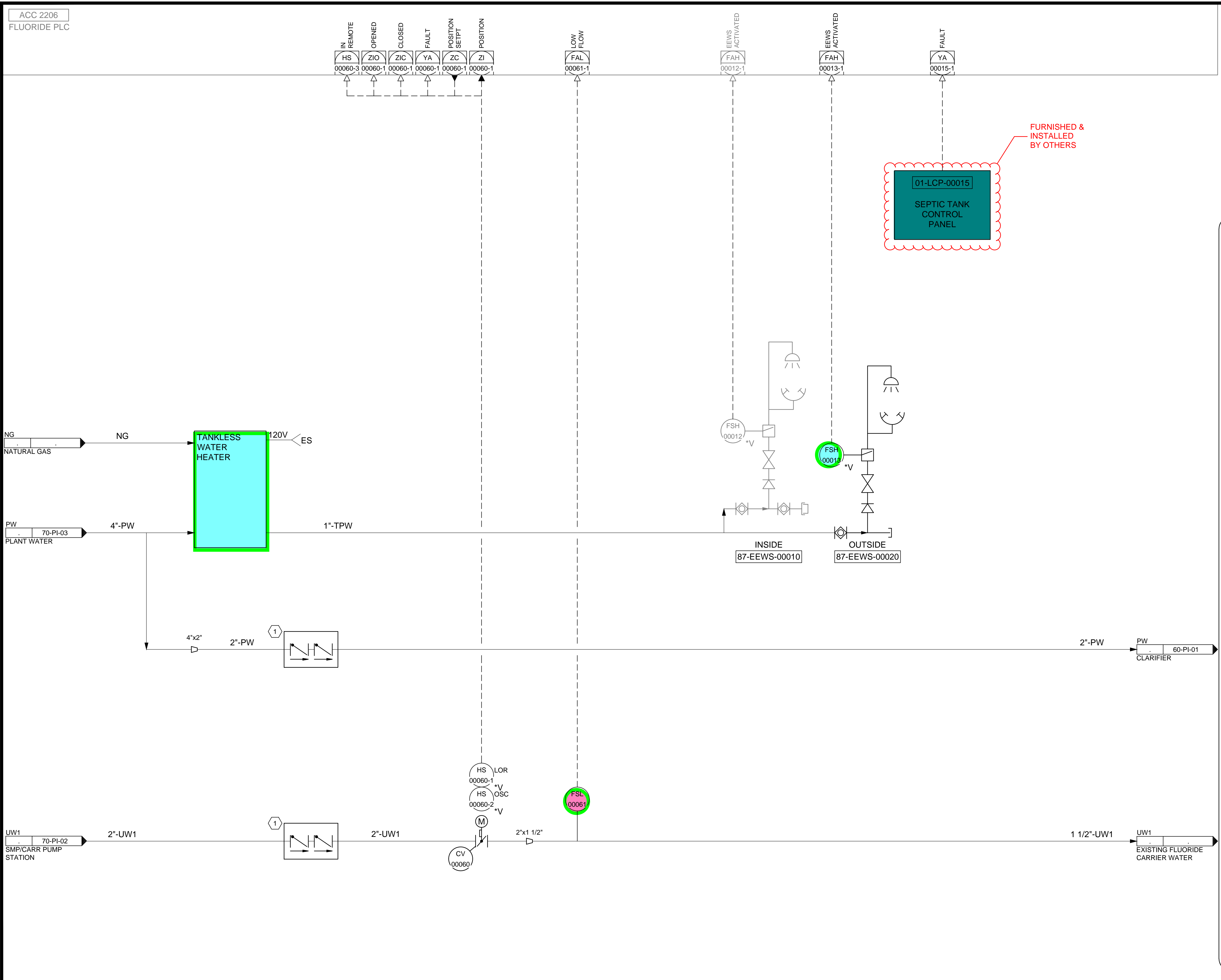

KEYNOTES:

1 PROVIDE BACKFLOW PREVENTER

Brown and Caldwell

ACC 2206
FLUORIDE PLC

DESIGNED BY: BOTANI
DRAWN BY: ALAPIERE
CHECKED BY: ALAPIERE
APPROVED BY: BOTANI
DATE: JUNE 2024
EWO NO: ---
ACCOUNT NO: 512260079

SCALE: _____

VERIFY SCALE
BAR IS ONE INCH ON ORIGINAL DRAWING

NO.	DATE	REVISIONS	MADE BY	AUTH BY
0	06/14/24	ISSUED FOR GUARANTEE MAXIMUM PRICE (GMP)	BO	BO

SALT LAKE CITY DEPARTMENT OF PUBLIC UTILITIES
CITY CREEK TREATMENT PLANT UPGRADES
BRIC PACKAGE
EXISTING FLUORIDE STORAGE

SALT LAKE CITY

90% GMP

DRAWING NO.
87-PI-01